

# Standardized A-Kit / Vehicle Envelope (SAVE)

*An Interface Description Document for  
C5ISR Systems Integration into Army Ground Vehicles*

Distribution A - Approved for Public Release, Distribution is Unlimited



PEO GCS, PL CTPI  
Detroit Arsenal, MI  
February 2022  
version 1.0

This page intentionally left blank.

## **Executive Summary**

This is the Standardized A-Kit / Vehicle Envelope, or "SAVE" standard. This Interface Description Document (IDD) describes the size and shape of a standard mounting location and set of physical interfaces for integration of Command, Control, Computers, Communications, Cyber, Intelligence, Surveillance, and Reconnaissance (C5ISR) systems into Army ground vehicles. It is intended to provide long term predictability and stability for vehicle and systems development. SAVE was initially developed for radios but also applies to computers and other systems such as the Integrated Visual Augmentation System (IVAS) vehicle integration kit and its Tactical Cloud Package (TCP), the CMOSS Mounted Form Factor (CMFF) first instantiation of the C5ISR Modular Open Suite of Standards (CMOSS), Electronic Warfare (EW) kits, etc. SAVE is a subset of the overall PEO GCS Common Infrastructure Architecture (GCIA) - the over-arching framework for an in-vehicle network to facilitate the integration of radios, computers, networks, etc., into ground combat vehicles. GCIA prescribes a modular open systems approach (MOSA), using Vehicular Integration for C4ISR/EW Interoperability (VICTORY) and other open interface standards for data sharing, enabling CMOSS and other MOSA benefits. SAVE is one of the physical portions of system integration within GCIA. SAVE also applies to PEO CS&CSS and other platforms that have no dependency on GCIA.

This IDD documents SAVE as an appropriate compromise between rigid Military Specifications and loose general descriptions. While this is not a contractual requirement document, to facilitate re-use of language in this IDD by PMs in their requests for proposal (RFPs) and other contracts we use language such as "shall" and "must" to indicate requirements to comply with SAVE, versus "should" or "may" to indicate design suggestions that are not required to be SAVE compliant.

SAVE incorporates the standards negotiated between platform PMs and PM TR/PdM HMS MP during HMS MP ("Handheld, Manpack, and Small Form Fit – Manpack" a multi-function data radio/SINCGARS replacement) development in the 2013 timeframe, per the "Platform Requirements for the HMS Manpack System Full Rate Production (FRP)" memo dated 20 March 2013. We intend to build upon this progress, expanding to include all current and future radios, and other C5ISR systems.

Ground vehicle program offices and C5ISR system program offices have agreed that adopting SAVE should allow significant reduction in cost and schedule when integrating new C5ISR system technology into ground platforms. Platforms will provide a standardized integration space and connections for C5ISR systems, and system PMs will acquire C5ISR devices which fit into this space and use these connections either natively or via adapters (mounting trays, cables, etc.) which the system vendor or PM provides. SAVE will not eliminate the need for NRE or safety testing, but in most cases it should accelerate the process.

By specifying only the outer envelope (maximum dimensions) and by providing for a range of possible connection configurations within this envelope, significant flexibility is retained for competitive acquisition. C5ISR systems can still come in a variety of sizes and shapes, and different connection techniques can be adapted as well. Our intent is to enable rapid flexible acquisition of advancing technology at competitive costs, while maintaining sufficient constraints to avoid prohibitive cost and schedule for vehicle integrations.

This page intentionally left blank.

# Table of Contents

---

1.	Introduction .....	1-1
1.1.	Background and Motivation.....	1-2
1.2.	SAVE Implementation Plan .....	1-3
1.3.	Relationship to Other Standards.....	1-4
1.4.	Intended Use of This Document .....	1-5
1.5.	A-Kit vs. B-Kit.....	1-6
1.6.	SAVE Standard Maintenance and Updates.....	1-9
2.	SAVE Physical Attributes .....	2-10
2.1.	Dimensions and Connection Locations .....	2-11
2.2.	Weight.....	2-13
2.3.	External Amplifiers.....	2-13
2.4.	Remote Human Machine Interface.....	2-14
2.5.	Installation and Accessibility.....	2-14
2.6.	Color.....	2-15
3.	SAVE Connectors and Connection Patterns .....	3-16
3.1.	RF Connectors and Cables.....	3-16
3.2.	Power .....	3-19
3.3.	Data .....	3-20
3.4.	Intercom (speakers / headsets).....	3-21
3.5.	Mounting Tray/Plate Provisions.....	3-23
4.	SAVE Environmental Tolerances.....	4-25
4.1.	Thermal Loading.....	4-26
4.2.	Environmental Testing.....	4-26
5.	Information Assurance and Cybersecurity.....	5-27
6.	Manuals and other Logistics and Sustainment.....	6-28
7.	Examples and Caveats.....	7-29
8.	Subdivision for Smaller Devices .....	8-32
9.	Future Extensions.....	9-34
10.	Conclusion .....	10-35
1.	Appendixes .....	10-36
1.1.	Abbreviations and Acronyms.....	10-36
1.2.	Technical References .....	10-38
1.3.	Change Log.....	10-38

# List of Figures

---

Figure 1. SAVE Envelope: Maximum Volume Allowed for SAVE Compliant Systems, Minimum Volume Provided by SAVE Compliant Vehicles .....	2-10
Figure 2. Example wiring for a Dual HMS MP with 2 MBAs.....	3-18
Figure 3. Example wiring for a Dual HMS MP with 4 MBAs.....	3-19
Figure 4. Rear M-1151 Vehicle Mount Audio Interface Connector.....	3-21
Figure 5. MIL-DTL-55116 Front Radio Audio Interface Connector.....	3-23
Figure 6. SINCGARS mounting hole pattern .....	3-24
Figure 7. SAVE mounting hole pattern.....	3-24
Figure 8. SINCGARS is SAVE compliant - except for Ethernet connections .....	7-29
Figure 9. Collins Aerospace Dual HMS MP is SAVE compliant.....	7-29
Figure 10. Notional platform with 4 SAVE envelopes - e.g. for Command or Retrans .....	7-30
Figure 11. Notional platform with 3 SAVE envelopes .....	7-30
Figure 12. Examples of hardware installations that would be SAVE compliant.....	7-31
Figure 13. More efficient example of 5 devices sharing a single SAVE envelope .....	8-32
Figure 14. Less efficient example of 3 devices sharing a single SAVE envelope.....	8-33

# List of Tables

---

Table 1. A-Kit versus B-Kit .....	1-7
Table 2. SAVE Dimensions.....	2-12
Table 3. Summary Table of SAVE Connectors.....	3-16
Table 4. Rear Vehicle Mount Audio Connector Pin Mapping.....	3-22
Table 5. MIL-DTL-55116 Front Radio Audio Connector Pin Mapping.....	3-23

# 1. Introduction

This document describes the Standardized A-Kit / Vehicle Envelope (SAVE) - the size and shape of a standard mounting location, or "envelope," and set of physical and electrical interfaces for C5ISR system integration into Army ground vehicles. The SAVE standard is intended to provide a clear and well-defined boundary for integration of C5ISR systems in vehicles, adding long term stable predictability for vehicle and C5ISR system developers. The SAVE standard is an agreement between ground vehicle program offices and C5ISR system program offices. Discussion amongst PMs led to agreement that this will provide a significant reduction in time and resources to integrate new C5ISR system technology into ground platforms. Platforms will provide a standardized integration space for C5ISR systems, and system PMs will acquire C5ISR systems which fit in this space - either natively or via adapter trays and connectors as required. This will allow rapid and affordable technology update cycles on both the vehicle and system side, enabling the United States Army to maintain operational overmatch with near peer competitors in combat.

SAVE is intended to apply to any modular system electrically and/or digitally integrated into an Army platform. It is not intended to cover stowed equipment, vehicle intrinsic elements such as engines or weapons, or intrinsically external components such as antennas or armor. It may, however, apply to elements of systems such as a computer controller for an active protection system.

This document is organized into sections that cover various aspects of the SAVE standard; compliance with all sections is necessary to fully meet the standard. Each element of compliance is beneficial in its own right, but these characteristics together were identified as those which drive integration costs.

Section 2 - Physical - size & shape of the SAVE envelope and related aspects such as which sides cables must be able to connect to;

Section 3 - Connectors - types of connectors for power, RF, etc., and patterns for how radios are wired to antennas

Section 4 - Environmental - requirements for vibration, temperature, electromagnetic effects, etc.

SAVE does not cover cybersecurity, information assurance, or co-site interference – it is focused on internal physical aspects only. Many other standards cover these issues, such as ATP 6-02.53 appendix H covers co-site. SAVE is intended to remain bounded to internal C5ISR system physical integration challenge.

SAVE will also help with Logistics and Sustainment (Section 6) with rules following the pattern established in the sections listed above.

In this IDD "A-Kit" refers to the components managed/owned/provided by the vehicle PM, as opposed to the "B-Kit" components provided by the C5ISR system PM. See section 1.5 for more details and examples of A-Kit versus B-Kit.

This is a living document that will evolve based on the needs of the platform and C5ISR communities. Please review this document critically and send any suggestions for improvement to [usarmy.detroit.peo-gcs.mbx.SAVE@army.mil](mailto:usarmy.detroit.peo-gcs.mbx.SAVE@army.mil) and we will work to improve it. In addition we will update this document as needed to capture any changes, caveats, or

non-compliances and distribute to ensure that stakeholders are aware. Vehicle specific modifications or additional restrictions will be added as annexes as required. We will also review with PEO leaders on at least an annual basis to ensure that the stakeholders remain engaged and in agreement. The latest version can be found at: <https://kcp.army.mil/sites/apeosei/mosa/documents/SAVE>

## **1.1. Background and Motivation**

There is clear and pervasive direction from senior Army leadership to accelerate the pace of technology upgrades. Adversaries have learned how to defeat the 30-year-old radios currently fielded in our ground combat vehicles and are outpacing our technology updates in general. It is likely that any future C5ISR system will require updates at least as frequent as every few years to remain tactically viable.

The objective is to make installation of C5ISR systems in Army Vehicles as simple as the installation of appliances at home – where power, gas, etc. connections are already standardized, and appliances are purchased to fit in the available space rather than, for example, re-building a kitchen around a new refrigerator. The intent of SAVE is to work together to achieve this same sort of standardization for ground combat platforms and C5ISR systems. Radios and Waveforms now change faster than the standard ground platform integration timeline, so some sort of accelerating change is required. SAVE will provide part of that acceleration.

Exacerbating this problem are congressionally mandated multi-vendor and non-developmental approaches to C5ISR system acquisition. These impose additional challenges, leading to cost & schedule growth. Unstable funding over protracted periods of time cause additional problems that can be mitigated by accelerating fielding timelines.

In addition, in the near future we expect to field new platform Mounted Capability Sets (M-CS) which will include new systems that will change frequently such as:

- New radios,
- New waveforms,
- A new Assured Position Navigation Timing (A-PNT) system,
- New Electronic Warfare (EW) systems,
- Vehicle Protective Systems (VPS) components and subsystems,
- Kit to harmoniously synchronize dismounted Soldier electronics with vehicle electronics (e.g. IVAS Mounted Soldier, and Nett-Warrior support kits), and
- Ubiquitous use of robotic systems in partnership with manned ground vehicles.

The expectation based on current planning from the Network Cross Functional Team and Army Futures Command is that there will be updated technology in capabilities sets on a two-year cycle. Thus, it is imperative that the Army community develop faster methods to safely and effectively integrate rapidly changing C5ISR systems into ground combat platforms.

The long-term objective of the SAVE standard is to render fielding C5ISR systems to ground vehicles as simple as fielding C5ISR systems to dismounted Soldiers. Training will be required, and the C5ISR systems must previously be vetted for performance,



environmental survivability, and system of systems compatibility, but lengthy new NRE cycles should not be required. New vehicles can be designed around, for example, a “SAVE Compliant Data Radio” instead of a specific vendor or model number; and design can safely begin years before the radio is available. It is unlikely that NRE and testing will be reduced to zero, and these will vary by C5ISR system and Platform, but with full adoption SAVE should greatly reduce the timelines required.

It will take time to reach a high level of standardization and compatibility, but in the meantime incremental steps of increasingly standardized systems and vehicles will yield increasing cost and schedule benefits. Adopting SAVE is not an all or nothing endeavor. We have already made significant steps in this direction, and savings are already being realized as a result.

## **1.2. SAVE Implementation Plan**

The implementation plan for SAVE begins with Assistant Secretary of the Army for Acquisition Logistics and Technology (ASA(ALT)) acceptance of this document as applicable to all Army PEOs. Subsequently this document, or the specifications in this document, will be included as requirements in new C5ISR system acquisitions, new vehicle acquisitions, and any new integration effort. Where full incorporation is not practical, exceptions should be negotiated between vehicle and system PMs, and Army Capability Managers (ACMs). PdL GCPI will help facilitate these negotiations.

The initial objective is to implement the first generation of SAVE compatibility during M-CS fielding to SBCT and ABCT formations, and during new vehicle acquisitions.

SAVE can also be included in new vehicle recapitalization or refresh efforts. It is intended to become part of existing vehicle and system upgrades, not to force a separate independent effort just to adapt vehicles or systems to the SAVE standard.

In most cases this will result in relatively minor cost changes to an existing effort. The current HMS MP radios are mostly SAVE compliant already, and integration efforts to accommodate these radios are therefore also mostly SAVE compliant. Full compliance may require the addition of a few extra cables or cable paths to ensure future flexibility. The key focus going forward will be on including SAVE standards in acquisition programs for future systems, such as CMFF and the Optionally Manned Fighting Vehicle (OMFV), so that integrating standard Army equipment is much easier in standard Army platforms. Cost/benefit analyses will be required when considering SAVE updates to integration efforts already underway, or when integrating into difficult to modify legacy vehicles.

The focus will also be on a paradigm shift in how the community considers integration into vehicles. For example, instead of contracting an effort to integrate a PRC-155 LRIP HMS MP radio into a vehicle variant, one would contract an effort to add a SAVE compliant C5ISR system envelope into that vehicle. The initial integration effort would require the standard cost and time, plus some additional cost to provide future upgrade flexibility as specified here, but subsequent integration of SAVE compliant C5ISR systems to that vehicle would require only minimal cost and schedule. More importantly, new vehicles can be designed around an appropriate number of SAVE compliant devices years before those devices are

available, and still retain high confidence that they can be readily integrated at the appropriate time.

Imagine that by 2028 we have fielded not only robust, resilient, and highly capable C5ISR systems and integrated tactical networks to our forward units, but that we have also acquired the ability to upgrade those systems across all of these modernized brigades in a matter of months instead of years at a fraction of the current cost. That is the ultimate motivation for the SAVE standard.

### **1.3. Relationship to Other Standards**

SAVE is intended to nest within the GCIA standard and to be compatible with and to supplement VICTORY, CMOSS, SOSA and other current standards that are in use or being developed to help move the Army to better MOSA architectures in our combat platforms. SAVE covers the purely physical elements while other standards focus on the data flowing between systems and the logical organization of those systems within a vehicle. For example, rather than calling for any specific VICTORY component types or versions here, we refer to the current CMOSS and VICTORY documentation for such details.

GCIA - the PEO GCS Common Infrastructure Architecture - provides a common vision for PEO GCS platforms for how components are connected logically inside of vehicles and where open interfaces exist to allow modular replacement of systems, enabling upgrade and re-use of individual capabilities within and between platforms. It provides a ready to use open systems architecture and software modules, with common GCS applications and services, and standard interface specifications, as well as common scope language and test strategies. The intent is to enable platform PMs to more rapidly coordinate MOSA processes in contracting with industry providers, and to ensure cross compatibility within GCS. GCIA incorporates SAVE to cover the physical size and shape of components.

The VICTORY standard, which is also incorporated within GCIA, further specifies data types for messages sent between devices on platforms - such as the underlying Ethernet standard, PNT messages, Radio Control messages, etc. between systems. VICTORY also does not specify connectors or physical attributes, and so does not overlap or conflict with SAVE.

CMOSS is a suite of standards that cover connection and data interfaces for card or modular devices within a common chassis to provide multiple functionalities within a smaller space. CMOSS does cover some physical attributes of systems, but only internal to a CMOSS compliant device (CMFF being the first), while SAVE covers the outer envelope and external interfaces of that device. The first CMFF systems will fit within a SAVE envelope, with SAVE specifying external interfaces while the CMOSS standard covers internal interfaces and data specifications over those interfaces. CMOSS also includes the VICTORY standard and is compatible with GCIA, as devices can be organized within CMFF and communicate with each other using GCIA principles and software. It will be important as CMOSS and SAVE evolve to ensure that they remain compatible with clear delineation of areas of responsibility.

The SOSA (Sensor Open Systems Architecture) initiative is another new standard that will complement SAVE. It has been added to the CMOSS standard. Formed as a Consortium of

The Open Group, SOSA addresses the challenges of rapid, affordable capability evolution for today's military community, focused on electromagnetic sensor technology. Part of the SOSA approach is to develop an Open Systems Architecture (OSA), captured in the SOSA Technical Standard, that addresses software, hardware, and interfaces. This OSA is designed to promote software, hardware, and interface portability and create product families across the Communications, EO/IR, EW, Radar, and SIGINT community. The SOSA Technical Standard is intended to promote the development of reusable sensor components applicable to a broad class of sensors and host platforms. The SOSA standard focuses on software and architectural aspects as opposed to the physical volume focus of SAVE. Both standards call out MIL-DTL-38999/Series III connectors, though SOSA provides more detailed specifications for data and signal connections and SAVE provides more options for power connections. Where there is overlap, either connector standard may be used (more detail is provided in Table 3 – Summary Table of Save Connectors). As both standards evolve, we will work to avoid overlap or conflicts between SAVE and SOSA.

## **1.4. Intended Use of This Document**

The management approach for SAVE is centralized planning with de-centralized execution. This is written as an IDD to avoid the challenges and intrinsically brittle nature of providing an interface control document (ICD) or a formal specification document. The implementation of SAVE will vary with each platform, new technology will dictate shifts in design by the C5ISR systems, and thus it is anticipated that some exceptions from both sides will be required. Our intent is to allow enough flexibility for affordable and prompt adoption by all PMs involved, while providing enough guidance to ensure that the implementations developed by each vehicle PM have a high probability of supporting all new C5ISR systems acquired over the next decade.

The intent for SAVE is that C5ISR system PMs and vehicle PMs adopt, include, or reference appropriate pieces of this document as a threshold requirement in future acquisitions in whatever form is most appropriate for their acquisition process. This will include adapting the requirements here to appropriate language in their RFPs and other legal/contractual documents. To facilitate re-use of language in this IDD, we use terms like "shall" and "must" to indicate requirements to comply with SAVE, versus terms like "should" or "may" to indicate design suggestions that are not required to be SAVE compliant. Modification to the SAVE requirements should be coordinated between system and vehicle PMs - PdL GCPI can assist with this coordination.

Coordination is still required between PEOs and with Army Capability Managers (ACMs) to determine the correct number of SAVE envelopes required per vehicle role. Cost/Benefit analyses will be required and a complete specification for all vehicles and roles is beyond the scope of this document.

It is assumed that C5ISR PMs will develop and coordinate batches of equipment to fit within a single SAVE envelope where appropriate – e.g. for CS fielding where multiple small systems are required. It would be inefficient and unnecessary to allocate an entire SAVE envelope for each small item. This empowers PEO C3T with flexibility to develop and evolve their system of systems approach while platform PMs can provide a long-term

stable space within which to do so. Section 8 suggests compatible sizes to design towards with smaller devices, to facilitate sharing SAVE slots.

Vehicle PMs will upgrade to SAVE standards as part of each new C5ISR system integration so that the vehicle acquires not only capability to host the current system, but also compatibility with any future SAVE compliant C5ISR system. They will also include as threshold requirements that any new vehicle include an appropriate number of SAVE envelopes based on its anticipated role (e.g. 1 for CMFF or a data radio system and 1 for CS support equipment in a simple vehicle role, while a command vehicle role may require 3 for POP equipment, 2 for additional RF equipment, and 1 for additional compute capability, with 6 envelopes total, etc.). Vehicle PMs must work with their ACMs to determine the appropriate number.

Distinction is included in this document regarding what constitutes A-Kit (Platform PM responsibility) versus B-Kit (C5ISR PM responsibility) and the interfaces between them. The intent here is to provide complete clarity of the interface points between the vehicle and the system so that development of C5ISR systems and vehicles can occur independently while retaining a high confidence that modern systems will readily integrate into modern vehicles.

The intent is also that the SAVE standard will be socialized to industry so that they can adapt their efforts in new product development accordingly. Thus, with wide and fair distribution of this intent, competitive pressure will automatically move industry towards SAVE compliance even without direct Government investments. The SAVE standard leaves plenty of room for innovation within the SAVE volume, it simply requires industry to not build systems that are, for example, too large or power hungry for Army platforms to support.

Partial compliance with the SAVE standard will still provide partial benefit, so perfect implementation is not required for SAVE to provide value. Until otherwise directed, PEO GCS / PL Capability Transition & Product Integration (CTPI) / PdL Ground Combat Product Integration (GCPI) shall create and moderate IPTs as required to engage all necessary stakeholders and communicate updates and nuances of implementation. As exceptions are identified, PdL GCPI will facilitate negotiations between PMs and will facilitate capture of decisions in memorandums of agreement. These will also be added as appendices in this document to maintain visibility to all stakeholders.

## **1.5. A-Kit vs. B-Kit**

The following table provides further clarity about what is A-Kit provided by the vehicle versus what is B-Kit, provided by the C5ISR system vendor and/or PM. The SAVE concept is intended to allow designs where new B-Kit can be installed in vehicles without modification to A-Kit. It is anticipated that most C5ISR systems will require some level of adapter kit to meet the SAVE standard, in the form of connector adapters, extension cables, etc. These will be provided by the C5ISR system PM as part of the B-Kit. This could be either a requirement imposed on the system vendor, or additional interface components that the PM acquires separately & provides along with the primary system.

In general, the C5ISR system PM provides everything inside the SAVE envelope, and also some systems such as antennas and triplexers that may be mounted outside. Vehicle PMs provide power, RF, etc. connections coming from the vehicle to the SAVE envelope. These are only general requirements and may not apply in all cases given the wide range of roles for some platforms. For example, many FMTV platforms may not utilize any C5ISR equipment, whereas a Stryker platform almost certain to need at least two systems. For vehicles needing less systems, providing a path for RF, intercom and data cables instead of including the cables themselves in every platform is an economical and appropriate compromise. Vehicle PMs may determine in consultation with their ACMs whether to provide all cables in advance or just paths for cables to be installed as needed later.

In the case of a large System of Systems suite of equipment (e.g. PoP or SNE ) multiple SAVE envelopes will be required. An analysis by the vehicle and system PMs would be in order to effectively and efficiently utilize these envelopes. If it is determined that the last envelope is only partially filled then it may be appropriate to mount smaller components in a non-SAVE envelope location, or to share that location with other smaller systems. The intention going forward is that future generations of equipment will be designed at inception to be mounted in SAVE envelopes and to utilize those spaces efficiently.

**Table 1. A-Kit versus B-Kit**

A-Kit (Vehicle Provides)	B-Kit (C5ISR System PM Provides)
Metal plate physically attached to the vehicle providing a MT-6352 bolt hole pattern to mount the C5ISR system	Baseplate, Trays, Radios / Computers / etc., and connection hardware such as bolts, nuts, washers, etc.
Vehicle power cables	Any required power conditioning or routing beyond the basic vehicle power connections (see Section 3.2 Power)
RF cables between SAVE envelope and antennas  (See section 3.1 – discussions with ACMs about vehicle roles are required to determine the appropriate # of cables or cable paths to provide off the assembly line for each vehicle type)	Triplexers, Diplexers etc. to merge/split signals, RF connector adapters, RF angle connectors, etc. as required
Intercom systems throughout the vehicle per vehicle requirements, where already required by that vehicle; including addition of radio interface terminals (RIT) if required.  (Does not imply addition of intercoms to vehicles that do not already have this requirement. For families of vehicles where many do not but some do, providing a path	Handsets/Headsets & Loudspeakers that connect to the front of the radio, and connectors on the radio that can connect to standard intercoms

A-Kit (Vehicle Provides)	B-Kit (C5ISR System PM Provides)
for cabling to be added as appropriate is acceptable.)	
Ethernet data cables to vehicle C5ISR router when present, cable mounting locations at SAVE envelopes to facilitate additional cables between SAVE envelopes if required.  (Does not imply a requirement to add a router/switch where one is not already required by the vehicle)	Additional switching and routing between C5ISR systems as required beyond the connections provided by the vehicle, including cables between SAVE envelopes to connect C5ISR systems.
Serial cables to vehicle provided Mounted Assured PNT System, Inertial Navigation Unit, etc. as required if not satisfied by standard Ethernet links  (As above, this applies to systems already required on the vehicle side, interfacing to new C5ISR systems)	Antennas and RF Power Amplifiers
Software: updates as necessary for any digital integration of C5ISR components in the SAVE envelope to appropriate vehicle components, including associated cybersecurity, authority to operate, etc. testing & certifications. Not applicable if the vehicle has no digital systems interacting with the C5ISR components in the SAVE envelope.	Software: as necessary for digital integration of C5ISR components to appropriate vehicle components, and between C5ISR components in the same SAVE envelope or other SAVE envelopes on the vehicle, including associated cybersecurity, authority to operate, etc. testing & certifications.

This IDD serves as an agreement between PEOs that the vehicle PMs will handle the left column A-Kit and the C5ISR system PMs will handle the right column B-Kit. The clear delineation of responsibilities eases everyone's integration planning and development efforts going forward.

Note that software falls on both sides - the SAVE standard will not eliminate the need for close coordination on digital interaction between the vehicle and C5ISR systems, and collaboration to achieve the necessary performance, safety, and cybersecurity certifications required. It is expected that software updates will be key elements of future modernization.

Note that VIC (vehicle intercom / headsets) systems and the infrastructure required to enable additional radio connections to those systems where they already exist are not covered here. This is beyond the scope of the SAVE standard, though it is important that vehicle and system PMs coordinate and come to agreement on how to resolve this prior to

any modernization effort. As of this writing there is no general or universal agreement as to where this responsibility lies.

Also note that this does not replace the need for coordination between PMs prior to integration and fielding activities in general – many responsibilities and execution plans need to be worked out that are not covered here, and modifications to the above may be appropriate in some cases. Responsibility for costs are one example of coordination not covered by the SAVE IDD, and for many efforts A-Kit costs are covered by B-Kit owners.

## **1.6. SAVE Standard Maintenance and Updates**

This document will be routinely reviewed and updated, with PEO GCS / PL CTPI / PdL GCPI taking the lead for now, working in concert with all stakeholder PEOs and PMs. In general, changes will be accumulated throughout the year, to be briefed, reviewed, and adopted at the Network Modernization and Fielding Synchronization TEMs, typically bi-annual, hosted by PEO C3T and PEO GCS, or other similar network community gatherings. Ad hoc changes will be implemented and socialized on an accelerated schedule if required.

Key Stakeholders Include

PEO GCS: PM SPHS, PM MAV, PD MBTS, PM SBCT, PL MPF, PM MCS, PL CTPI

PEO CS&CSS: JPO JLTV, PM TS

PEO C3T: PM TR, PM MC, PM TN, PM I2S

PEO IEW&S: PM PNT, PM EW&C, PM IS&A

PEO Soldier: PM IVAS

Please send comments and suggestions, including additions to the stakeholder list above, to PEO GCS/PL CTPI/PdL GCPI:

usarmy.detroit.peo-gcs.mbx.SAVE@army.mil.

The current version of this document will be posted at:

<https://kcp.army.mil/sites/apeosei/mosa/documents/SAVE>

## 2. SAVE Physical Attributes

This section covers the physical envelope and connection points of SAVE. The concept of the physical envelope of the SAVE standard is illustrated in the figure below. Dimensions of the envelope are detailed in Section 2.1 below. This section also covers the physical locations (surfaces of the envelope) that cables must be able to reach. Note that environmental requirements are included as well. This is particularly key in heavily armored platforms which tend to have a) the most challenging requirements and b) the least amount of available space. If cooling fans or other mechanisms are required for a system to survive the specified environment, those mechanisms must also be contained within this envelope.

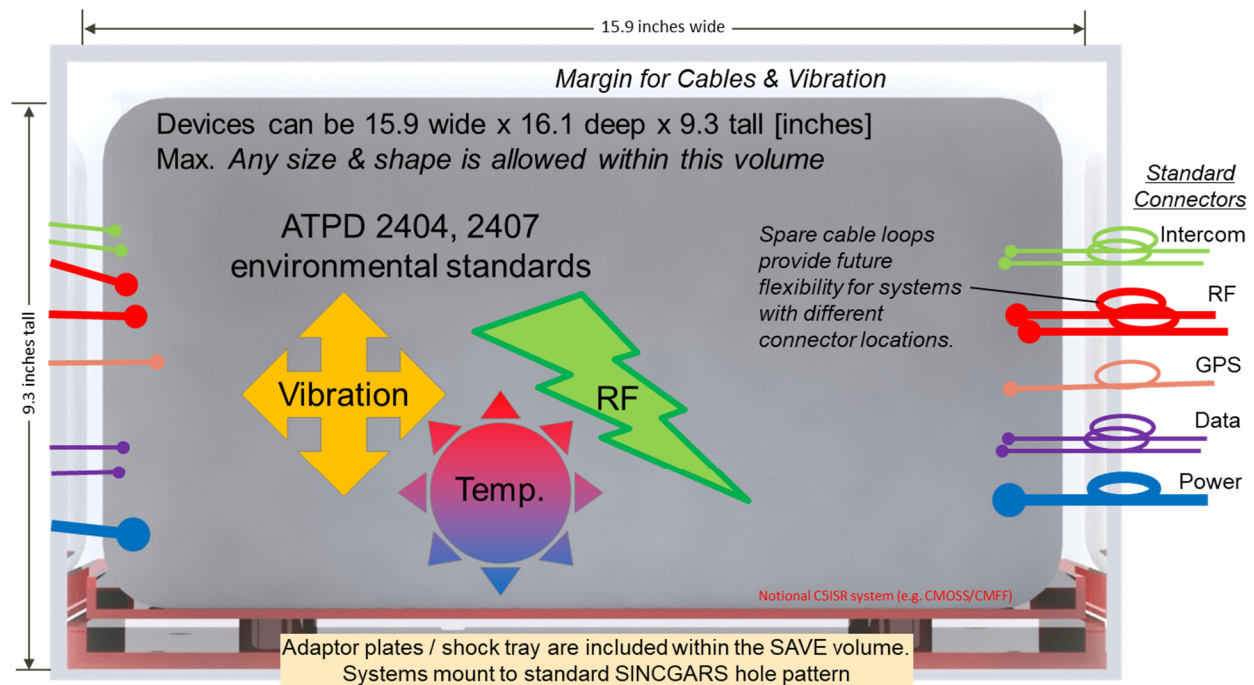

**Figure 1. SAVE Envelope: Maximum Volume Allowed for SAVE Compliant Systems, Minimum Volume Provided by SAVE Compliant Vehicles**

The oval loops in the diagram illustrate that cables shall be provisioned with additional length to allow for new attachments with the SAVE envelope or adjacent SAVE envelopes to future C5ISR systems. The exact spare length requirements are not specified as they will depend on vehicle dimensions, but are intended to be on the order of one to two feet to reach the necessary locations depending on vehicle rack layout, cable bend radius etc. It is not intended that enough spare cable be included to reach a non-adjacent SAVE location, e.g. externally or on the opposite side of the vehicle. This is discussed in more detail at the end of section 2.1 below.

SAVE was originally developed to hold a dual HMS MP Gen 2 four channel radio, but it can accommodate a wide range of C5ISR systems. The new CMFF radio/computer/APNT system shall fit within a SAVE envelope, and the new TCP on-board computing and routing capability to support IVAS is also being designed around the SAVE standard. SAVE can also



support any legacy SINCGARS radio, VRC-87 through VRC-91, with only a few RF cable adapters required. It also easily holds a Mounted leader Radio (VRC-135). It will not apply to all C5ISR systems, but compliance is possible for most of them. Going forward, the goal is to ensure that all future C5ISR systems can be incorporated into the SAVE envelope. However, this effort does not dictate retrofitting of vehicles or systems already fielded.

For radios, at least two amplifiers shall fit within the SAVE envelope where such amplifiers are required. For CMFF it is anticipated that they will mount on the antenna risers external to the vehicle, which is also acceptable assuming an appropriate design to meet survivability requirements. In general, all system ancillaries should fit within the SAVE envelope, except where there are significant technical reasons to do otherwise – such as mounting a triplexer close to an antenna to enable one long cable instead of three to support all bands, or where an amplifier must be mounted close to the antenna to minimize noise.

A vehicle may have several SAVE envelopes if multiple C5ISR systems are required, as is typical with Command or Retransmission roles. For example - in a vehicle intended to provide links between physically isolated networks - up to 6 channels of SINCGARS may be required. Thus the vehicle may need one SAVE envelope to hold a 4 channel dual HMS MP radio, and a second SAVE envelope to hold a 2 channel single HMS MP radio. Then the new CS equipment providing IVAS interfaces, radio routing, TCP etc., would likely require a third SAVE envelope to be added as well. The savvy vehicle designer should provide a fourth SAVE envelope as margin for future growth.

The following section details the physical dimensions of the SAVE envelope.

## **2.1. Dimensions and Connection Locations**

The table below provides dimensions and connection locations within a SAVE envelope. These dimensions shall be inclusive of baseplates, mounting trays, etc., i.e. from the bare metal of the vehicle. All baseplates and trays as well as radios, computers, etc. must fit within these overall dimensions. These represent the inner solid line shown in Figure 1 above. It is anticipated that in most cases one or more C5ISR systems will attach to some sort of baseplate or tray system with adapting hole patterns, which allows most existing systems to be adapted into a SAVE compliant version without modification to the system itself. This tray will usually perform a shock absorbing function as well.

Platforms shall provide a mounting plate suitable to hold the C5ISR system. Most vehicles have that capability today for a SINCGARS radio, providing the base for one SAVE envelope. Platforms that do not have a radio mounting location shall be responsible for adding one – for example adding a digi-rack to older HMMWV models to support both BFT installations and SINCGARS. Recall that while this falls on the vehicle side of the SAVE responsibility definitions, the assignment of responsibility for funding this or any related efforts is beyond the scope of this document and must be negotiated separately.

These are MAXIMUM dimensions for C5ISR systems - any size or shape within these dimensions is allowed, including mounting a tray system with multiple smaller radios or devices within a single SAVE envelope. This allows for significant flexibility in C5ISR system

design while stabilizing platform NRE efforts. Similarly platforms may provide larger spaces as SAVE envelopes.

Table 2 below summarizes the dimensional requirements. See Figure 1 above and Figure 7 below for clarity on which direction are width, height, and depth. Depth = 0 refers to the front face of the system, typically facing the crew compartment. Height = 0 refers to the base of the system, where it mounts to the vehicle.

**Table 2. SAVE Dimensions**

Dimension	Location	Notes
width (W)	15.9 inches	exactly fits SINCGARS mounting base
depth (D)	16.1 inches	fits SINCGARS VRC91
height (H)	9.3 inches	fits SINCGARS VRC91 (MP PRD uses 9.3" instead of 9.1")
vibration margin	1 inch sides & top 2 inches front & back	Vehicles should provide margin space around the SAVE envelope to allow for vibration / sway, installation, and cable runs. Where not practical, platform PMs shall provide appropriate vibration margin for their vehicles.
Connection Orientation	Straight or Right Angle	To facilitate flexible cable attachments maintaining appropriate bend radius while avoiding cable extension into crew compartments, Vehicle PMs shall use 90° connectors at the ends of vehicle provided cables. C5ISR PMs shall design system connection point locations and overall dimensions such that these mating connectors also fit within the SAVE envelope. Where C5ISR PMs provide cable adapters to non-standard connection types, these will also be provided with options for 90° bend attachment.
RF Cable Locations	Anywhere in front (D=0)	All C5ISR systems integrated to date have RF connections in the front. Vehicles will provide sufficient cable lengths for RF cable to reach the front of any SAVE location within the vehicle.
Power Cable Locations	Anywhere in back panel (D=16.1)	Power cables attach in the rear, and provide pass-through capability to enable powering other devices, as is done by the SINCGARS 6352 baseplate.
Headset Cable Locations	Front & Back (D=0, 16.1)	Front connections are easily accessible during missions to allow attachment/removal of handsets, headsets, etc. Rear connections integrate with vehicle intercom systems.
Data Cable Locations	Anywhere in front panel (D=0)	Must be accessible when C5ISR system is integrated into the vehicle.
Bolt Locations	(H=0)	Matching MT-6352 SINCGARS vehicular mounting base, see section 3.5, figure 7.
Ground Braid	As required to permit tray to be tied to vehicle structure	Vehicle racks must provide a proper ground path to the vehicle chassis. Where the vehicle tray may not provide the same or better ground to the vehicle structure, a low resistance ground braid of 10 milli Ohms max is to be provided. See MIL-HDBK-419A on grounds and bonds.

Cable management is a key issue in C5ISR system integration. Cables that route too far from the edge of a system can cause a hazard to Soldiers moving past the system, could be damaged, used as handholds, etc. Thus there is a requirement that C5ISR systems shall come with 90° adapters to allow platforms to route cables appropriately along the edges of

the SAVE volume. In some cases a radio may have handles that can be used to provide cable protection and in others it may be appropriate to provide similar cable protection on the vehicle side. As this varies significantly across platforms and systems, no single requirement for cable protection at the device interface is specified here.

In the case of a vehicle with multiple adjacent envelopes, the antenna and other cables shall be designed with sufficient lengths to extend to adjacent SAVE locations in the vehicle. This allows for future re-configuration, e.g. if a radio capability is absorbed into a future CMFF system the antenna connection could be shifted to that system without re-wiring the vehicle. This requirement is intended for configurations where SAVE locations are close together, so the amount of cabling required is reasonable, e.g. on Stryker platforms with 6 adjacent SAVE envelopes on the same equipment rack. Vehicles shall also provide mounting / storage locations for excess cable (e.g. holes for zip ties around cable loops, as already exist in Stryker equipment rack legs) to accommodate this. These mounting locations will also facilitate connections between C5ISR devices in different SAVE envelopes using short cables provided by the C5ISR PMs as B-Kit. These mounting locations will also facilitate cable control to prevent hazards as mentioned above. The details of locations of mounting points and the amount of additional cable are left to individual platform PMs to determine, as designs will vary based on vehicle geometry and the required bend radius of the selected cables.

In cases where there are large distances between SAVE envelopes (i.e. other end of the vehicle, external versus internal, hull versus turret, etc.), providing the ability to reach between SAVE envelopes is NOT required. Cable re-routing or addition of longer bridging cables will be done as additional integration work if and when systems require it.

## **2.2. Weight**

C5ISR systems shall not exceed 100 pounds for all items and support structures or equipment to be mounted within a single SAVE envelope. This limit is similar to the VRC-89 legacy SINCGARS radios (92.81 lbs) with a small margin. In addition, the system and its mounting tray and other ancillaries must be able to withstand shock and vibration per section 4 SAVE Environmental below.

Systems should be decomposable during installation to enable single Soldier installation, in compliance with MIL-STD-1472 Rev G and MANPRINT which call for a limit of 44lbs for individual Soldier lift items. (i.e. a full SINCGARS radio set weighs 100lbs, but the tray, RT, and amplifier are lifted separately.)

## **2.3. External Amplifiers**

One amplifier per RT shall fit within the SAVE envelope. For example, in a typical integration - e.g. a dual HMS MP four channel radio in a non-retransmission role - two amplifiers fit on the radio tray to amplify the SINCGARS (VHF) channels. In general, all system ancillaries should fit within the SAVE envelope. For future systems as waveforms evolve this should be interpreted to apply to any amplifiers, VHF is simply the current example.

If required, e.g. for a retransmission role where additional amplification is needed, amplifiers that must be mounted external to the SAVE envelope should not exceed the space claim of the existing SINCGARS amplifier - MT-6353 mount and AM-7238/A/B amplifier - i.e. 9"H x 5.8"W x 13.6"D per channel amplified.

In some vehicles, an additional SAVE envelope may be available that may be used to hold one or more external amplifiers or similar ancillaries (one SAVE location can typically hold at least two amplifiers). Alternately a custom location may be provided by the vehicle and must be negotiated on a vehicle/role specific basis.

## **2.4. Remote Human Machine Interface**

In many vehicles, the C5ISR systems must be mounted at a distance from the operators, e.g. in an equipment rack in the rear of or outside of the vehicle, such that a remote-control capability is required.

Where remote Soldier control is necessary, the C5ISR system must be compatible with current standard remote HMI applications to operate the C5ISR system from a host computer in the vehicle using applicable VICTORY and GCIA control messages, and compliant with Mounted COE standards. The intent is that the C5ISR system can be connected via Ethernet to a VICTORY compliant bus and controlled remotely by the MFoCS or other Soldier interface on the same VICTORY bus. Please see the current VICTORY and CMOSS standards (see Appendix 1.2) for details. We recognize that many current systems (e.g. SINCGARS) do not yet comply with this standard, but this is the intent for Army systems moving forward.

## **2.5. Installation and Accessibility**

The SAVE IDD is not intended to fully cover human factors– these are covered elsewhere, and requirements will vary by platform and system. Some key points are included here that are most likely to be relevant or which have caused problems in the past.

The primary C5ISR system components of the system (RTs) shall be able to be installed and removed in the field without any special tools or equipment. This allows for maintenance in tactical environments and dismounted operations.

The C5ISR system shall allow for access to RF and Data and Headset cables (front side connections) when integrated in an interior SAVE location. Power cabling and rear headset cabling (rear side connections) need not be accessible when the C5ISR systems are installed but must be accessible from the front plane when the primary system is removed (i.e. top, bottom, and side planes may be blocked by other systems or armor).

Data plates on primary C5ISR systems (with model/serial numbers) must be readable from the front plate without de-installing the system to facilitate Soldier inventories, per MIL-STD-130 IDENTIFICATION MARKING OF US MILITARY PROPERTY.

All human interfaces shall comply with MIL-STD-1472G regarding human factors to enable Soldier operation. These should already be included in requirements managed by the C5ISR

system PMs. Vehicle PMs will place SAVE envelopes in locations with appropriate front side accessibility or provide allowances for remote control systems.

The C5ISR system shall mount to an existing SINCGARS (MT-6352/VRC, P/N: A3013367-1, NSN: 5975-01-188-8873) tray or provide its own mounting tray that uses the same bolt pattern (see section 3.5 for details). Vehicles shall provide clearance below the mounting plate so that nuts can be accessed there.

Note that this section applies to "installation" of the RT or other field replaceable components, able to be done by Soldiers in the field, not to be confused with "integration" which refers to NRE and design work, as well as drilling, welding, etc. modifications to the vehicle to add A-Kit trays, cables, etc. to accept and support B-Kit when it is installed.

## **2.6. Color**

There is no requirement for color for SAVE compliant systems or mounting trays - they will be inside the vehicle so visibility or appearance are not critical criteria. Designers should use colors that optimize usability. In absence of other factors, olive drab green is a typical color for Army radios.

### 3. SAVE Connectors and Connection Patterns

This section covers the connection types specified by SAVE, and some examples of typical connection patterns for data radios. This table focuses on connections required for data radios – other types of C5ISR systems will not require all of these, and other systems may require connectors not included here. As appropriate, additional connector standards for other applications, e.g. camera system connections, will be added to the SAVE standard – suggestions are welcome.

**Table 3. Summary Table of SAVE Connectors**

Connection	#	Value	Notes
RF cables at radio	4	Type N, or TNC, BNC, 50 ohm	Primary radio RF cables shall be 50 ohm type N plug, to RT & Power Amplifiers as appropriate.
RF cables at antennas	3/ antenna	Type N, or TNC, BNC, 50 ohm; varies	The other end of the RF cables will vary depending on connections to amplifiers, triplexers, etc., per anticipated vehicle roles. Radio will come with triplexers, adapters, as needed.
RF - GPS	2	TNC, or SMA, 50 ohm	GPS cables shall be TNC or SMA plug
Power – Input (Higher power devices may require a different connector)	2	M55181/2-01, 4-PIN POWER or MIL-DTL-38999/Series III	Same as SINCGARS, 22-32 V DC per MIL-STD-1275. 27.5 V DC nominal. 600W, 50 A fuse. Or SOSA standard power connector.
Power – Output (Higher power devices may require a different connector)	2	M55181/4-01, 4-PIN POWER or MIL-DTL-38999/Series III	Allows power pass-through to other devices, per SINCGARS; or alternately a SOSA compliant connector may be used. Systems requiring higher than 35A may use appropriate larger cable connections.
Audio	4	M555181/8-01 18 PIN or equivalent	Per SINCGARS / Mil-Spec standard
Key Fill	as req.	MIL-DTL-55116	NSA P/N 0N241775
Data Cable Types		MIL-DTL-38999 Series III connector types with pinouts defined in MoD Def Stan 23-09 specification.	Connection count is vehicle dependent, no SAVE requirement.

#### 3.1. RF Connectors and Cables

For C5ISR systems that include radios, the system shall include whip and/or SATCOM antennas and adapters appropriate to that radio's capabilities. The primary link between each antenna location and the SAVE locations shall be a 50-ohm RF cable with type-N plug connectors (the radio will come with type-N receptacle connections). The cable shall allow for high power high frequency operation (through S-Band), with sufficient physical strength, electromagnetic (EM) shielding, and flexibility required to meet the platform

design. Signal attenuation must be the same or less than Times Microwave Systems LMR-400 (<https://www.timesmicrowave.com/DataSheets/CableProducts/LMR-400.pdf>), e.g. less than 16.8 dB/100 m at 1500 MHz, < 2.9 dB/100 m at 50 MHz, < 19.6 dB/100 m at 2000 MHz, etc.. Minimum bend radius will be a vehicle specific requirement so it will be left to each vehicle to specify this parameter as they choose specific cables. Cable design is an A-Kit item under the responsibility of the Vehicle PMs as specified above in table 2. Vehicle PMs may decide where to include the physical cables (e.g. vehicles where most vehicle roles require the RF system or where integration during assembly save significant difficulty), or to provide routing paths and passthroughs for cables to be added as needed (e.g. vehicles where only some roles / uses require the RF system).

All cables and connectors should be rated as IP-67 compliant (1m immersion) or better to tolerate frequently wet vehicle environments. Specifying “direct burial” cables for vehicles whose systems are subjected to internal and external washdown is highly recommended as there are reports of water intrusion in the cable and eventually into the connected hardware. “Direct Burial” provides an added layer of water resistance by injection of silicone into the braid.

Note that proper EM shielding of RF connections and cables is key to meeting nuclear hardening requirements and to mitigate hazards of electromagnetic radiation to ordinance, fuel, and personnel (HERO, HERF, HERP) particularly for direct fire turreted combat vehicles. Compliance with SAVE may help accelerate this testing, but it will not eliminate it.

Type N connections are used as the primary capability to allow for physically strong connections to high power high frequency cables that are also robust to military vehicle environments. The previous standard of BNC connectors for SINCGARS does not support sufficiently high frequencies for modern waveforms. Smaller connectors such as SMA can support higher frequencies, but are physically less robust, and may not be able to support sufficient power levels for long range transmissions for some waveforms. TNC connectors are also an acceptable compromise between strength and the ability to fit many connectors in a small space – e.g. for multi-antenna radios. The number of connections required varies by vehicle and role and is determined by Army Capability Managers (ACMs) and documented in the Network Basis of Issue (NBOI). The pacing design for RF cabling to a SAVE location is the dual HMS MP Radio. This radio has four channels, each covering 3 to 4 separate bands and / or a TACSAT capability. The multi-band whip antenna for terrestrial communications uses three separate connections for VHF, UHF, and L/S-Band. Vehicle PMs shall determine the appropriate number of antenna locations on their vehicle based on vehicle roles, vehicle space and other constraints, and as directed by appropriate ACMs. For each antenna required, Vehicle PMs shall run sufficient RF cabling to connect all bands on the antenna – e.g. 3 per channel for HMS MP radios, to cover current and future waveform requirements. Note that it is anticipated that future waveform requirements will change frequently and be added via radio software updates – all bands are to be wired to allow for these changes to occur without requiring hardware updates.

C5ISR PMs shall provide triplexers, amplifiers, and other ancillary devices as required.

Figure 2 below, provided for example purposes only, shows an HMS MP connection pattern for a vehicle constrained to two whip antenna locations.

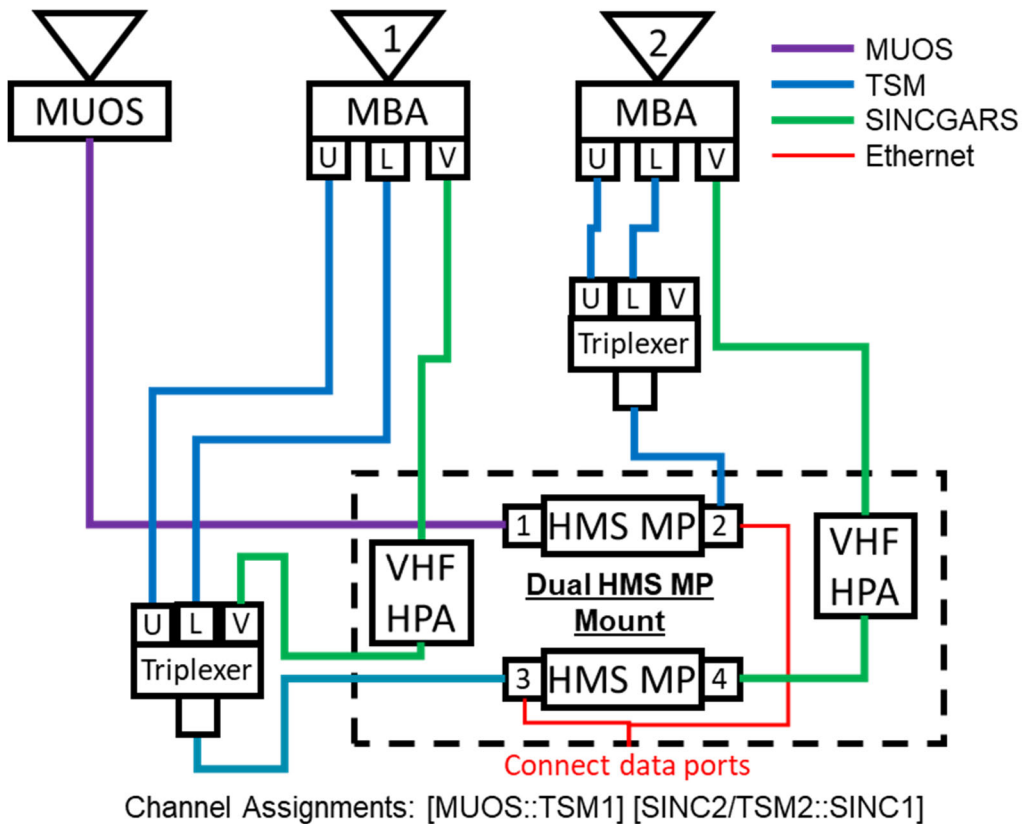

**Figure 2. Example wiring for a Dual HMS MP with 2 MBAs**

This design represents a typical compromise between maximum flexibility and minimum roof space required on the vehicle, appropriate for an average lower echelon vehicle role. The design provides one fixed WREN-TSM channel, one fixed SINGGARS channel, one fixed MUOS channel, and one channel that can flex between WREN-TSM and SINGGARS. The lower HMS MP is capable of either SINGGARS to WREN-TSM cross-banding or high power SINGGARS to SINGGARS retransmission.

Figure 3 below shows a more complicated four antenna design, appropriate for a command vehicle requiring more connectivity options. This represents a maximum flexibility configuration. It requires more roof space for antennas and significantly more cabling but allows each of the four channels to be either SINGGARS or WREN-TSM, and one to be MUOS as well. (Note that the RF switch to alternate between MUOS and WREN-TSM is available for the L3 Harris Gen 2 HMS MP but is still objective for the Collins Aerospace Gen 2 HMS MP.)



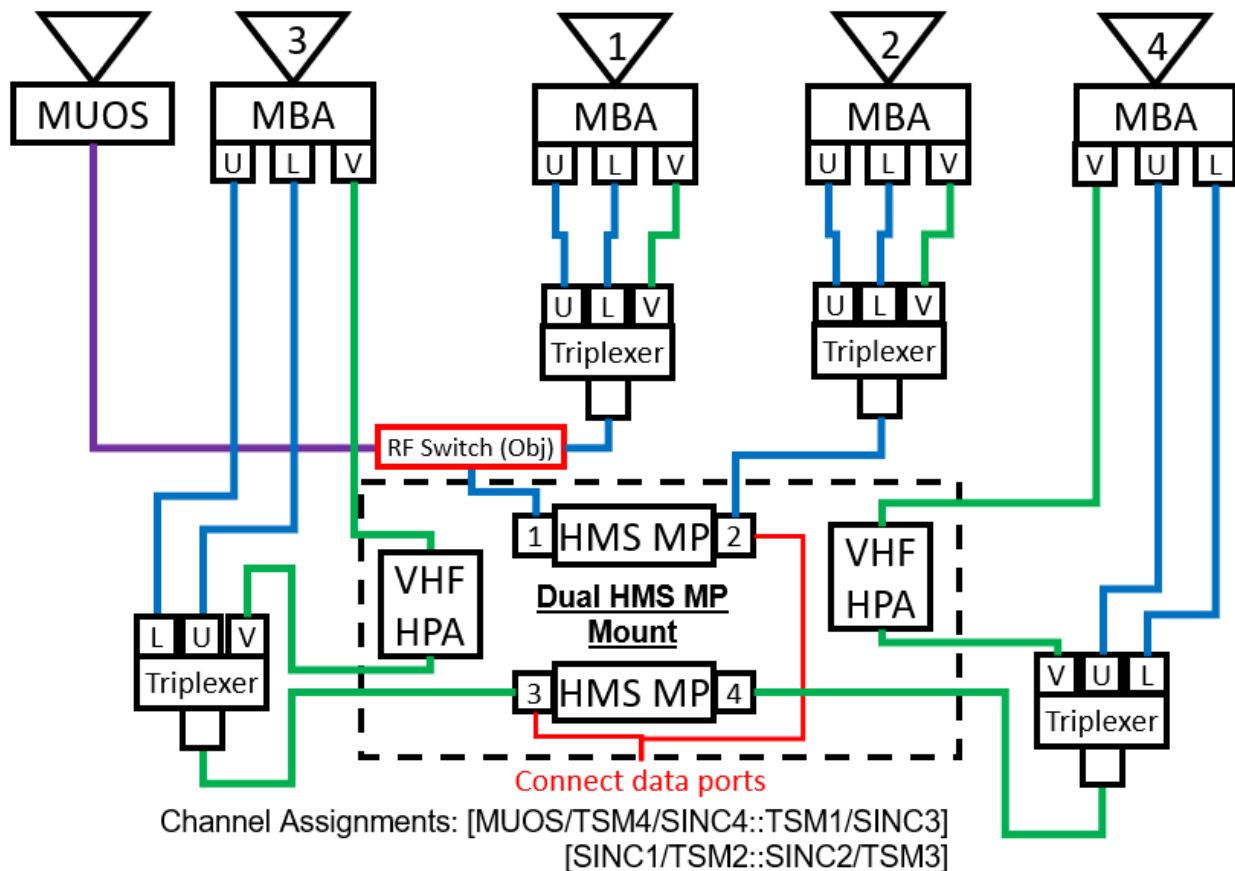

Figure 3. Example wiring for a Dual HMS MP with 4 MBAs

The wiring patterns and antenna counts in the figures above are provided only as examples to illustrate the type of connection decisions that must be made. PMs shall consult with vehicle, formation, and radio ACMs to determine the appropriate connection pattern for each vehicle type and role.

In general C5ISR systems must limit the number of antennas, and power levels of radiation, to low enough values to fit on existing vehicles without damaging Soldiers, other systems, or the vehicle itself. Co-site interference and other issues electromagnetic compatibility issues may limit a vehicle to fewer antennas than shown here. There is significant variance between vehicles and C5ISR system technologies that influence the appropriate limitations in this regard, so no specific value is included as a requirement within SAVE. These factors must be worked between platform and system PMs for each new system prior to integration.

### 3.2. Power

Power shall be in accordance with the current version of MIL-STD-1275 and power connectors shall be M55181/2-01 (input), M55181/4-01 (output) as used for SINGARS. Alternate connectors may also be MIL-DTL-38999/Series III per the SOSA standard. The C5ISR system tray shall have both input and output power connections, to allow connections to other devices nearby.

C5ISR systems shall comply with the current MIL-STD-1275 and will not draw more than 600 W peak power per SAVE slot. Higher power requirements must be negotiated between system and platform PMs as required. Note that a system which occupies two SAVE slots would have 1200W. This does not imply that all vehicles have sufficient power to provide 600W to all SAVE envelopes simultaneously – the overall system of systems power analysis must still be conducted for each integration effort involving multiple SAVE slots.

This number will be revised if CMOSS designs that fit in a single SAVE envelope require higher power levels. As of this writing, CMOSS/CMFF systems are still under development. If a system requires more than 35A then a different connector than the M55181 will be required, and an appropriate high current connector may be selected.

In some instances, the use of Commercial Off The Shelf (COTS) equipment is becoming more common. When available, the vehicle platform should provide AC power to the SAVE envelope to facilitate the use of COTS equipment.

This section will be updated if vehicles move to high voltage power systems - standards for connections and adapters will be provided as they become available.

### **3.3. Data**

The primary data connection shall be Ethernet and as a minimum, comply with ANSI/TIA-568.2-D Cat 6A. This is in compliance with DoD and Army policy adopting a Modular Open Systems Approach, as captured in the CMOSS/VICTORY standards and the PEO GCS GCIA standard. It is anticipated that all Army systems are converging towards a common Ethernet digital backbone going forward. Connectors shall be military standard ruggedized types with water and dust proofing. The SOSA standard provides additional guidance on data connectors. To maintain data rates, the twists per inch and shielding standards must be maintained inside devices (e.g. between a signal entry panel and internal sub-components) as well as in connectors and cables between devices.

The SAVE IDD does not impose a requirement for a vehicle to have one or more C5ISR or vehicle data enclaves, so there is no requirement in the SAVE IDD covering the number of Ethernet connections the vehicle or system shall provide. For simple vehicles such as the HMMWV with one SAVE envelope and no need for a data connection, it may not be appropriate for the PM to provide any data connections. C5ISR PMs may simply provide a cable running between the radio and the mission command computer, for example. For complicated vehicles with multiple SAVE envelopes and other C5ISR equipment (e.g. Command platforms), it may be most effective for the vehicle to provide a common C5ISR switch to coordinate these devices and to connect to other vehicle functions if needed. This is a system of systems design choice and beyond the scope of the SAVE IDD. If C5ISR systems being added to vehicles require more data routing/switching between devices beyond the capacity or capability provided by a vehicle, it shall be the responsibility of PM MC to provide additional routing/switching as needed.

The cybersecurity and classification impacts of connections between vehicles and C5ISR devices is beyond the scope of the SAVE IDD and must be negotiated between Vehicle and C5ISR PMs as usual. This includes requirements such as spacing and shielding between cables carrying data at different classification levels.

If the C5ISR systems are implemented such as to add a cross-domain requirement to a vehicle where no Cross-Domain Solution (CDS) is already present which can accommodate the data flow, then the C5ISR system shall provide a CDS as well, also within the SAVE envelope. If the platform does have a CDS, coordination will be required to determine the appropriate connections and sharing or duplication of functionality.

Where required, systems shall provide cryptological key and software/firmware mission data loading connectors that conform with standard United States Government and NATO Crypto and Mission Data Loaders. The SAVE IDD does not alter the current connector requirements for these systems. In terms of physical location, these connections shall be accessible from the front panel of any C5ISR system requiring them. It has been suggested that a Zeroize Bus be implemented in the case where multiple devices require that function. Consideration should be given to tying these inputs together in a bus arrangement so as to provide a single switch for activation. It is outside the scope of this document to require this feature but platform and system PMs should consider adding this where possible.

### 3.4. Intercom (speakers / headsets)

C5ISR systems requiring a voice interface shall provide the standard 31 pin mount to Speaker / Headset / VIC-3 systems on the rear of the tray as SINCGARS does today - M55181/8-01, on the MT-6352 SINCGARS baseplate. Eventually these analog connections will be replaced by VICTORY standards and the Ethernet bus, but for now compatibility with legacy systems is required.

In addition to the rear interface, C5ISR systems shall also provide a redundant standard audio / data connector on the front – following the 7 pin MIL-DTL-55116, suitable for standard loudspeaker, handset, and VIC-3 connection.

The following diagrams and tables are provided as an example, where in this case the front headset connector is also a serial data connector, used to fill crypto-key or GPS data, or to connect a data link to a Fires device such as AFATDS.

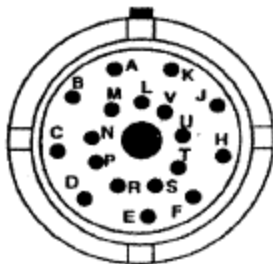
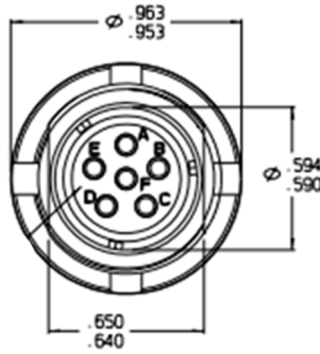

Figure 4. Rear M-1151 Vehicle Mount Audio Interface Connector

**Table 4. Rear Vehicle Mount Audio Connector Pin Mapping**

Pin	Name	Description	I/ O	Characteristics
A	GND	Ground	-	Power / Signal Return
B	PRIME DC POWER	Vehicle Power	0	+27.5VDC 0.5A (nominal) protected by 8 A non-resettable fuse
C	SW DC POWER	Switched Vehicle Power	0	+27.5VDC 0.5A (nominal) protected by 8 A non-resettable fuse
D	REMOTE POWER RELAY CONTROL	Control Input wired OR'ed with other VIC connectors	I	OFF=0V ON=>22VDC
E	SPARE	NA	--	--
F	SPARE	NA	--	--
H	ICS-D VIC RCV AUDIO	Low Level Rcv audio	--	NOT USED
J	SPARE	NA	--	--
K	ICS-D FIXED AUDIO	Lower Manpack CH1 Receive Audio	0	0.780Vrms at 600Ω, 300-3KHz Signals to/from Lower Manpack CH1 Single-ended (converted to differential)
L	SPARE	NA	--	--
M	SPARE	NA	--	--
N	SPARE	NA	--	--
P	SPARE	NA	--	--
R	SPARE	NA	--	--
S	ICC-D PTT-N	Lower Manpack CH1 PTT	I	GND=TX (<150Ω), OPEN=INACTIVE
T	SPARE	NA	--	--
U	ICS-D XMT AUDIO	Lower Manpack CH1 Transmit audio	I	280mVrms+/-2dB, C(load)<100pF, R(load)>20K Signals to/from Lower Manpack CH1 Single-ended (converted to differential)
V	SPARE	NA	--	--



**Figure 5. MIL-DTL-55116 Front Radio Audio Interface Connector**

**Table 5. MIL-DTL-55116 Front Radio Audio Connector Pin Mapping**

Pin	Audio	Sync. Data	RS-232	DS-101 Key Fill	DS-101 GPS Fill
A	GND	GND	GND	GND	GND
B	Ear Audio	RX Data	RXD	Data +	Flow Control Out
C	PTT	PTT	RTS/PTT	NC	Data In
D	Mic Audio	Clock	NC	NC	Data Out
E	NC	NC	CTS	Data -	Flow Control In
F	Mic Bias	TX Data	TXD	NC	KP_F

### 3.5. Mounting Tray/Plate Provisions

Vehicle PMs shall provide SAVE locations with bolt hole patterns compatible with standard SINCGARS MT-6352 mounting trays. C5ISR system PMs shall provide systems, or adapter trays, that connect to this bolt pattern, using mounting slots instead of holes to allow for flexibility of system placement front to back. Full sized devices shall use 3" mounting slots as documented in the diagrams below. Smaller devices may use smaller slots as appropriate. When multiple devices are mounted, or devices that are small enough that the current mounting holes are not appropriately positioned, an adapter plate may be used to provide an alternative hole pattern as appropriate. Mounting bolts to the vehicle tray shall be standard 5/16" bolts as are used with SINCGARS today, and mounting holes for C5ISR systems or adapter plates shall be 3/8", for ease of installation.

The hole pattern in a SINCGARS baseplate is illustrated in Figure 6 below as a convenient example for those familiar with the SINCGARS system. The left half shows the entire 6352 tray, while the right half of the figure shows only the lower mounting plate with the shock absorber system removed to expose the mounting holes. The SAVE mounting hole pattern was designed around the SINCGARS pattern, but with slots instead of holes to increase flexibility. The slots allow slightly different mounting locations in different vehicles.

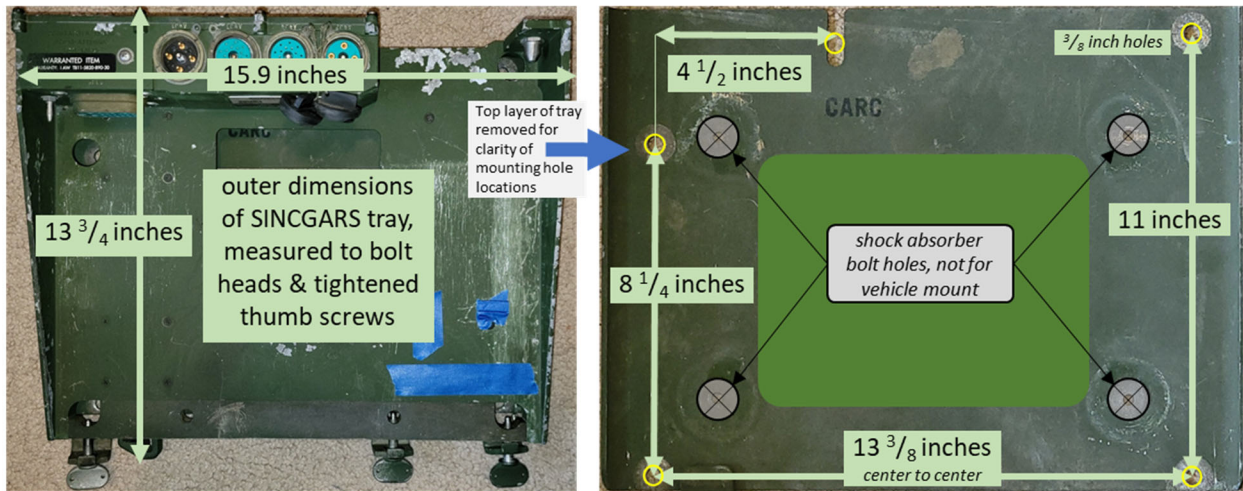

**Figure 6. SINGGARS mounting hole pattern**

The SAVE mounting hole pattern is illustrated in Figure 7 below. The vehicle mounting holes will remain the same as the current holes, aligned to the SINGGARS pattern. New devices shall provide 3" mounting slots as shown below to allow for optimal positioning of each device relative to the crew area in the front and any obstructions or cable paths in the rear. This will provide maximum compatibility with a range of legacy vehicles with slightly different mounting trays.

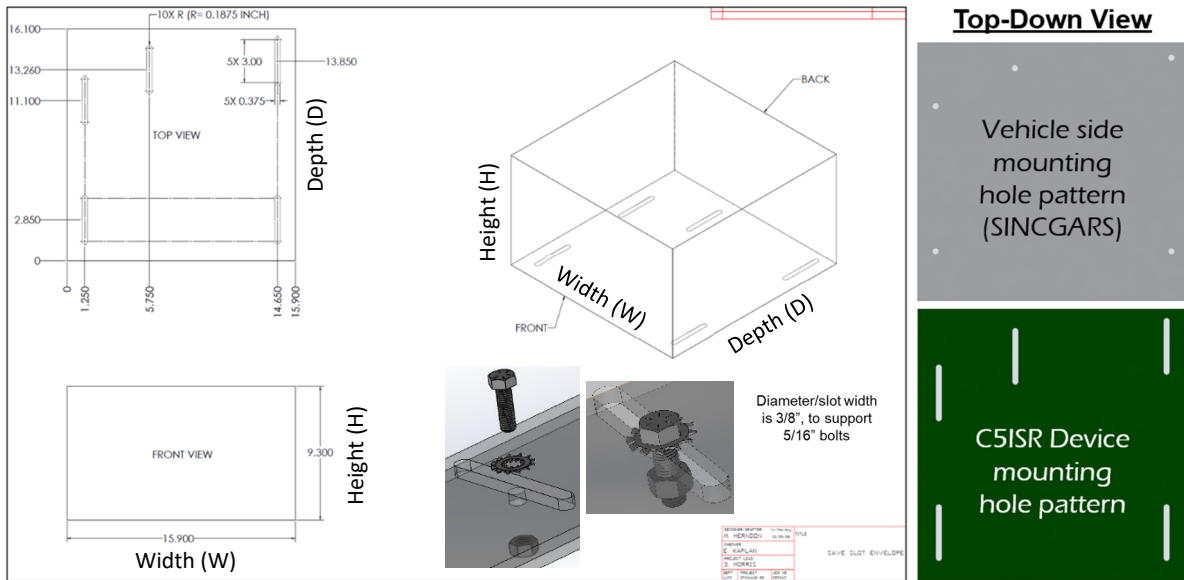

**Figure 7. SAVE mounting hole pattern**

## 4. SAVE Environmental Tolerances

The environmental conditions required to be fully compliant in a SAVE envelope are specified in the current ATPD-2404 - "Interface Standard Environmental Conditions for Ground Combat Systems". These cover the worst-case conditions required by armored platforms, including shock, vibration, minimum and maximum temperatures, and nuclear hardening. Note that most SAVE envelopes will be mounted interior to the vehicle and thus subjected to the induced internal environment (71C), as opposed the external ambient environment (51C plus solar loading). Actual environments will vary by vehicle and mounting configuration, designing to the worst case load will ensure compatibility with all platforms.

Note that ACM analysis has determined that the nuclear hardening requirement applies only to "mission essential" systems - i.e. those whose failure would remove the vehicle's ability to move, shoot, or communicate. System PMs should consult with their ACMs and ACMs for the vehicles and formations wherein it may be fielded to determine where their system falls with regards to this requirement.

ATPD-2404 includes reference to AR 705-35 - specs on transportation shock & vibration – which includes air drop environmental conditions. Abrams and Bradley vehicles do not have an air drop requirement, but to be compatible with ALL Army vehicles SAVE compliant devices shall tolerate the air drop shock loads listed there as well if they may be mounted in a vehicle with an air drop requirement - such as some HMMWVs in Airborne IBCTs.

Systems shall also comply with the current version of ATPD-2407 - "Electromagnetic Environmental Effects (E3) for US Army Tank and Automotive Vehicle Systems Tailored From MIL-STD-464C". The TACOM E3 Requirements Board (E3RB) developed and maintains ATPD-2407, which tailors the requirements in MIL-STD-464 to those relevant to Army ground vehicles. 2407 considers any electrical components installed on a vehicle to be a subsystem within the requirements specified in MIL-STD-461. Some requirements in 2407 are more stringent than the general 461 standard and some are less, as appropriate to the ground combat vehicle environment.

While the worst case constraints in 2404 and 2407 do not necessarily apply to ALL platforms in ABCTs or other formations, C5ISR systems that do not meet these requirements may not be able to be fielded to the heavy platforms in ABCTs. It will be up to the C5ISR PMs and discussions between ACMs to determine requirements and a proper approach if these requirements become cost prohibitive, e.g. developing multiple versions of systems if the hardening creates a high per-unit cost, adding waivers or alteration of definitions of "critical systems" in platforms, etc.

C5ISR PMs should reach out to GCS PMs to discuss requirements in detail - it has been found in the past that hardening does not typically drastically increase component costs (in one example, nuclear hardening for displays and keyboards ended up costing only 15 cents per unit to add a small protective circuit), though the development and testing costs can be significant. Tapping into proper expertise and using careful component selection can make

nuclear hardening straightforward. Please reach out to [usarmy.detroit.peo-gcs.mbx.SAVE@army.mil](mailto:usarmy.detroit.peo-gcs.mbx.SAVE@army.mil) for the latest versions of these standards and with any questions.

## **4.1. Thermal Loading**

There are no specific thermal loading requirements within the SAVE standard except to state that the C5ISR system must survive the platform environment as discussed above. Engineering of heat dissipation due to power consumed by a device is out of scope of SAVE.

Note that combat platforms are generally tightly packed without much space for airflow. The SAVE mounting plate will be metal with good electrical conductivity but may be connected to other equipment racks by only relatively small metal brackets, allowing only some thermal conductivity. The air surrounding the SAVE environment, particularly in the rear, may be still dead air. Ideally C5ISR systems are designed to passively handle the initial ambient temperature and any internal heating during active use within this environment. But this is not a specific requirement, only an implementation suggestion.

Platform PMs shall determine appropriate maximum thermal loading inside vehicles from all C5ISR and other systems installed there. Limitations on thermal output are a system of systems problem, and so outside the scope of the SAVE IDD. MIL-STD-1472G on human factors provides requirements regarding temperature safety for contact surfaces and environments in general - those requirements are not altered here.

## **4.2. Environmental Testing**

C5ISR systems shall be tested to this standard in a laboratory environment and on an appropriate set of test vehicles. Subsequently these systems should be approved for most integrations in most SAVE compliant platforms with reduced, or in some cases no, platform specific environmental tests. The platforms, in turn, will have completed SAVE compliance testing during initial integrations, verifying that SAVE location environmental conditions do comply with the standard. This may require more rigorous testing initially but will reduce testing costs for any subsequent C5ISR system upgrade.

It is not anticipated that compliance with SAVE will be able to *eliminate* safety and system of systems tests, just that SAVE will streamline and accelerate the process. Specific testing requirements shall still be negotiated between Platform and C5ISR PMs and ATEC based on platform type and risks specific to each platform and system combination.



## **5. Information Assurance and Cybersecurity**

The SAVE IDD deals with the physical interface standards and does not contain any additional standards for information assurance or cybersecurity. Vehicles and C5ISR systems must comply with the normal cybersecurity, TEMPEST, risk management framework (RMF), Authority to Operate (ATO), etc. requirements specified in Army acquisition requirements and program system security plans. As per the normal process, C5ISR PMs will share RMF and related materials with Platform PMs to facilitate Platform cybersecurity and certifications, and vice-versa.

## 6. Manuals and other Logistics and Sustainment

Under the SAVE standard and GCIA in general, a similar boundary exists for responsibility for Log products as described in the A-Kit/B-Kit table in section 1. C5ISR PMs are responsible for documentation covering systems that go inside the SAVE envelope, while Vehicle PMs are responsible for any documentation for the vehicle system and any specific variations from the SAVE IDD that may require additional instruction. The C5ISR system PM shall provide installation, operation, and maintenance instructions with the system appropriate to a SAVE compliant location in any vehicle. This documentation can assume that location has the appropriate mounting holes, cabling, and connector types and that those are clearly labelled.

The vehicle PM shall provide any instructions required due to any variation from the SAVE standards present in that vehicle in their vehicle tech manuals etc. Otherwise vehicle operating instructions will refer to the C5ISR system instructions for components within the SAVE envelopes rather than vehicle PMs having to create and maintain independent radio operating instructions or other C5ISR system related documentation.

The boundary for replacement parts and sustainment processes is the same as the SAVE boundary, with external elements falling under the Platform PM, and internal elements falling under the C5ISR PM, with further clarification provided by the A-Kit and B-Kit table in section 1.5 above. There is overlap in software responsibility that must be negotiated for each system-platform combination.

Note that funding for Logistics and other activities, particularly for initial SAVE implementation, may come from different sources than the PM responsible for implementation. It is outside the scope of the SAVE IDD to specify funding responsibilities.

## 7. Examples and Caveats

This section shows some examples of common C5ISR systems in SAVE locations, and examples in vehicles of how/where a SAVE envelope may be implemented. There are no additional requirements in this section. The intent of this section is to provide additional clarity about what is intended with the SAVE standard. In most cases vehicles already have SAVE compliant locations, except for the full complement of connections.

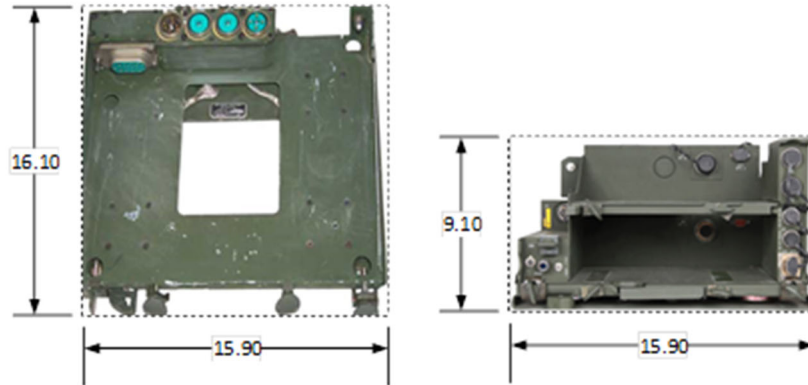

Figure 8. SINGARS is SAVE compliant - except for Ethernet connections

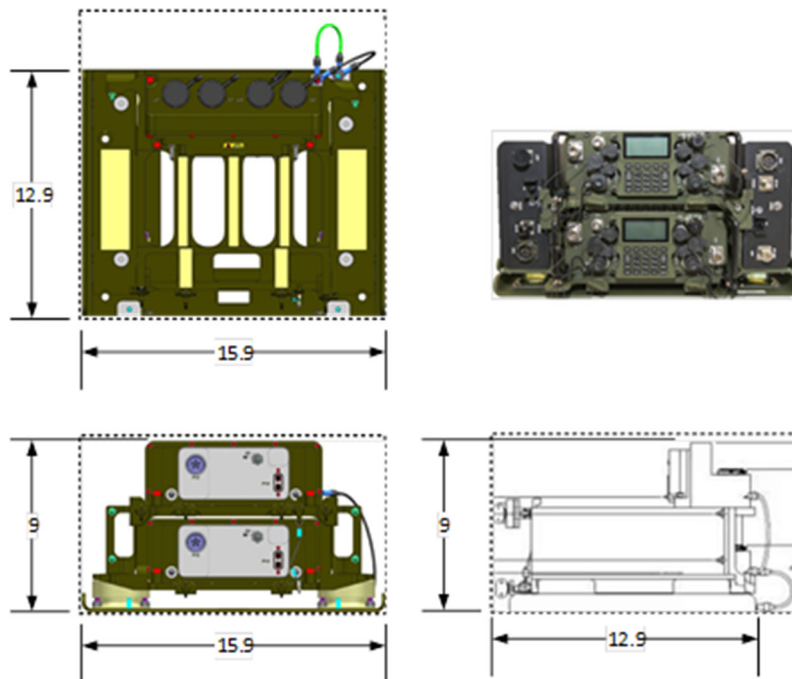
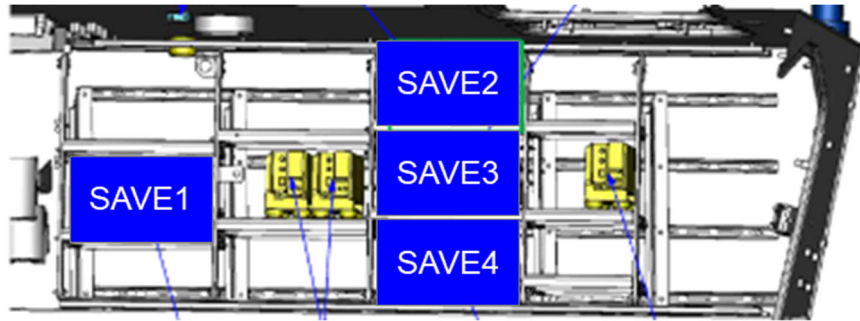

Figure 9. Collins Aerospace Dual HMS MP is SAVE compliant

The figure below shows what a high-end configuration may look like in a ground combat platform. Note that minimal change to a current rack-based design is required to be SAVE

compliant. Some changes would be needed to cabling and connectors but otherwise the current design is already compliant. Similarly Figure 10 shows possible locations in a combat support vehicle. These figures are notional examples only to illustrate the concept, not actual current vehicles or designs.



**Figure 10. Notional platform with 4 SAVE envelopes - e.g. for Command or Retrans**

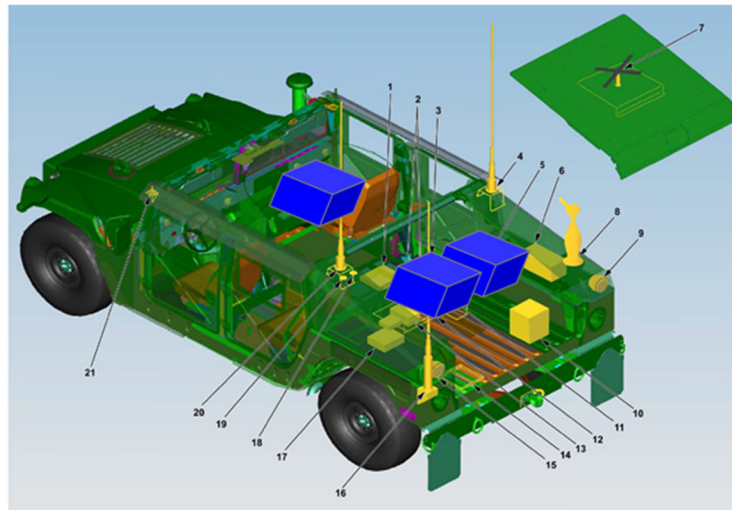

**Figure 11. Notional platform with 3 SAVE envelopes**



**Figure 12. Examples of hardware installations that would be SAVE compliant**

One example of a known exception is the VRC-104 (PRC-150 / PRC-160) HF radio - which has dimensions that exceed the SAVE standard. This generation of HF radio will require custom mounting solutions and will not be compatible with SAVE locations. The objective is that the next generation HF radio will be reduced in size to meet the SAVE standard.

Challenges are anticipated in some vehicle locations relating to non-rectangular armor, vehicle ventilation systems, or other infrastructure that impacts the SAVE volume. Platform PMs will work with C5ISR PMs to resolve conflicts or find alternate locations where these occur.

## 8. Subdivision for Smaller Devices

Many devices will be smaller than the SAVE standard, and this will become more common as technology for current systems advances. To facilitate sharing of SAVE envelopes, the following guidance and suggestions are provided. To avoid constraints on innovation, this section does not contain any strict requirements. In future versions of SAVE requirements may be added as appropriate standards emerge.

Multiple systems may share a SAVE envelope. A shared SAVE envelope may or may not contain a common mounting tray. To facilitate efficient sharing of SAVE envelopes, it is recommended to constrain narrow device width to 7.5" (1/2) or 5.3" (1/3) or multiples thereof to enable two or three devices to be mounted side by side, with or without a common shock tray. It is recommended that short device height be limited to 4" to allow two devices to be mounted top to bottom, with margin for trays and shock mounts.

For all sizes it is recommended that the wiring connections specified above be followed, with connectors in the front and back and mounting bolts on the bottom. This avoids adjacent devices blocking cable routing.

The diagrams below show two possible examples of a mounting brackets for multiple devices in a single SAVE envelope.

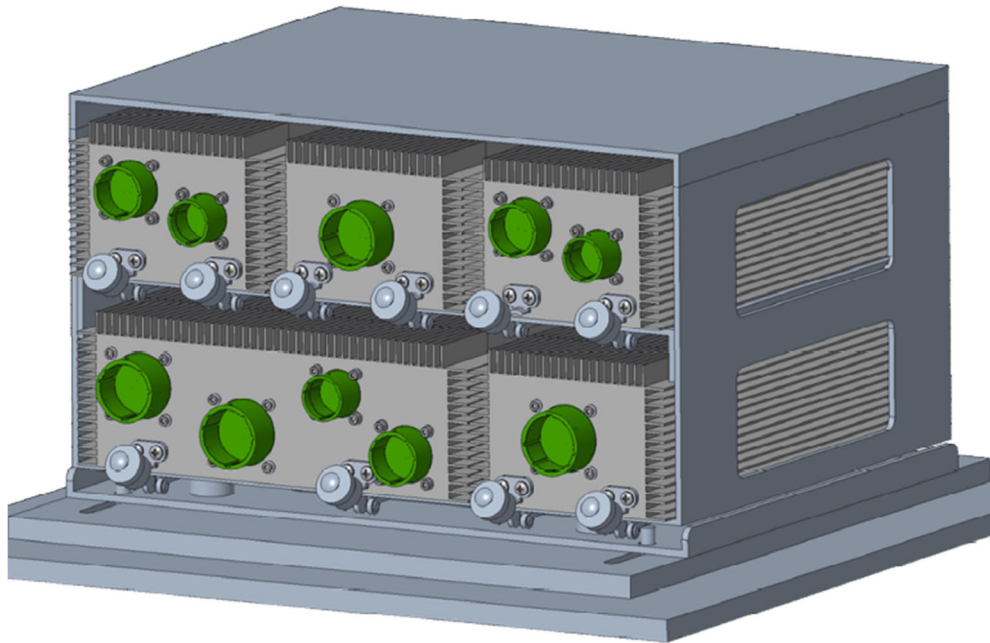

**Figure 13. More efficient example of 5 devices sharing a single SAVE envelope**

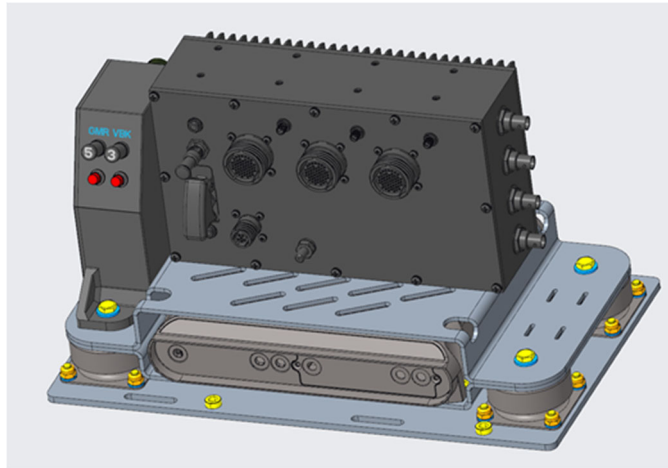

**Figure 14. Less efficient example of 3 devices sharing a single SAVE envelope.**

In this case the taller device and shorter device work well together, though they require a custom tray. Connections on the side are not recommended, as these inhibit use of space on that side as can be seen in the figure.

There is no strict requirement for subdividing a SAVE envelope at this time. Suggestions for standardization for multiple devices within a SAVE envelope are welcomed, and if consensus between Army and Industry stakeholders can be achieved, it will be included in future versions of the SAVE standard.

## 9. Future Extensions

This section is included to solicit additional inputs about how to improve or extend the SAVE standard. There are no additional requirements in this section. It is included to engage the stakeholder community in future improvements to SAVE.

A wireless connection standard is needed to connect C5ISR systems in Army vehicles - e.g. radios, laptops, headsets, handheld C2 systems, etc., but we do not yet have a standard that we can specify as with Ethernet above. Currently the de-facto standard is 802.11ac (WiFi, 5GHz). This needs to evolve for security reasons into a more robust military version of the protocol, ideally in the 10-60GHz frequency range to reduce spurious propagation. Various efforts are underway towards this and if possible we will add this specification and associated physical mounting standards here in the future. Suggestions on how to approach this are encouraged.

SAVE does not cover antenna mounting. While whip antennas are well covered by existing NATO standards, recent discussions have suggested that a similar standard to cover SATCOM antennas would provide significant benefit, particularly with the drive towards adding additional LEO/MEO SATCOM capabilities. Please reach out if you have ideas in this area.

A similar standard to cover external RF amplifiers mounted on or near antenna risers, as envisioned for CMFF, may be appropriate – for the same reasons that motivate the SAVE standard. An important consideration will be armor requirements, and definitions of “Mission Critical” that drive under armor versus over armor requirements. If you have inputs as to what should be included for an external RF amplifier mounting standard, please let us know.

There also may be opportunities to unify or at least provide improved compatibility between the SAVE standard and standards used in military aircraft or watercraft. If you have inputs or suggestions about how to do this, please let us know.

Suggestions to implement or improve these extensions or any other aspects of the SAVE standard are welcome. Please reach out to [usarmy.detroit.peo-gcs.mbx.SAVE@army.mil](mailto:usarmy.detroit.peo-gcs.mbx.SAVE@army.mil). Suggested changes will be socialized at community TEMs and also feedback will be directly sought from appropriate stakeholders. Updated versions will be submitted for review and approval as discussed in section 1.6 above.



## **10. Conclusion**

The SAVE standard is intended to provide a clear and well-defined boundary for integration of C5ISR systems in vehicles, adding long term stable predictability for vehicle and C5ISR system developers. With the interfaces locked down, innovative solutions can be developed within these boundaries in parallel with vehicle development, allowing faster initial development, reduced integration costs, and - most importantly - rapid update cycles for compliant systems on compliant vehicles.

# 1. Appendixes

## 1.1. Abbreviations and Acronyms

<b><u>Acronym</u></b>	<b><u>Definition / Explanation</u></b>
A	ampere - international system of units measure of electrical current
ABCT	Armored Brigade Combat Team (with Bradley, Abrams, AMPV, etc. heavy platforms)
ACM	Army Capability Manager
AFATDS	Advanced Field Artillery Tactical Data System
APEO	Assistant Program Executive Office
A-PNT	Assured Position Navigation Timing
ATPD	Automotive Tank Purchase Description
BNC	"Bayonet Neill-Concelman" - a small connector used for coaxial cables carrying signals between a radio and an antenna, used at lower frequencies
C2	Command and Control
C3T	Command Control and Communications - Tactical
C5ISR	Command, Control, Communications, Computers, Cyber, Intelligence, Surveillance and Reconnaissance
CDS	Cross Domain Solution
CMOSS	C5ISR Modular Open Suite of Standards
CMFF	CMOSS Mounted Form Factor (planned first instantiation of CMOSS)
COE	Common Operating Environment
CS	Capability Set – Army Futures Command network modernization process
CS&CSS	Combat Service & Combat Service Support (JLTV, HMMWV, MTV, LTV etc.)
CTPI	Capability Transition & Product Integration
EW	Electronic Warfare
GCIA	PEO GCS Common Infrastructure Architecture
GCPI	Ground Combat Product Integration
GCS	Ground Combat Systems
GPS	Global Positioning System
HMMWV	High-Mobility Multipurpose Wheeled Vehicle
HMS MP	Handheld, Manpack, and Small Form Fit – Manpack, modern data radio
Hz	Hertz – unit of measurement of frequency for wireless communications
IVAS	Integrated Visual Augmentation System
JBC-P	Joint Battle Command – Platform – command and control software, uses the BFT2 network, and MFOCS or JV5 computers in Army vehicles.
L-Band	Long wave – IEEE band designation for 1 to 2 GHz frequencies
LEO/MEO	Low Earth Orbit / Mid-Earth Orbit – references a new generation of commercial SATCOM capabilities coming in the early 2020s.
M-CS	Mounted Capability Set
MANET	Mobile Ad-hoc Networking (self-forming networks that relay data between nodes to extend range)

MBA	Multi-Band Antenna
MFoCS	Mounted Family of Computer Systems
MUOS	Mobile User Objective System – new global voice beyond line of sight communications
N	The N connector (also, type-N connector) is a threaded, weatherproof, medium-size RF connector used to join coaxial cables.
Ohm	International System of Units measure of electrical resistance
OMFV	Optionally Manned Fighting Vehicle
PEO	Program Executive Office
PM	Program Manager
PRC-155	Low Rate Initial Production (LRIP) version of the HMS MP radio
RF	Radio Frequency – i.e. wireless communications
RT	Receiver / Transmitter
S-Band	Short wave – IEEE band designation for 2 to 4 GHz frequencies
SE&I	Systems Engineering and Integration
SINCGARS	Single Channel Ground and Airborne Radio System
SMA	“SubMiniature version A” – a miniature connector used for coaxial cables carrying signals between a radio and an antenna, used at high frequencies
SOSA	Sensor Open Systems Architecture
TACSAT	Tactical Satellite – legacy global voice beyond line of sight communications
TCP	Tactical Cloud Package – previously known as Bloodhound
TEM	Technical Exchange Meeting
TEMPEST	Telecommunications Electronics Materials Protected from Emanating Spurious Transmissions
TR	Tactical Radios
TSM	Tactical Scalable MANET (new voice + data waveform)
TSM	Tactical Scalable MANET – new voice + data waveform
UHF	Ultra-High Frequency – IEEE band designation for 300 to 1000 MHz
V DC	Volts, Direct Current
V rms	Volts, root mean square
VHF	Very High Frequency – IEEE band designation for 30 to 300 MHz
VIC-3	AN/VIC-3 is the standard VIS for Army ground vehicles over the last two decades.
VICTORY	Vehicular Integration for C4ISR/EW InTerOpeRabilitY
VIS	Vehicle Intercommunication System
VRC	Vehicle Radio Communications (Army / Navy nomenclature designation)
W	Watts
WREN	Warrior Robust Enhanced Networking waveform (incorporates TSM + lower bandwidth modes + Secret modes)

## 1.2. Technical References

<u>Document</u>	<u>Title</u>	<u>Date</u>
AR 705-35	Criteria for Air Portability and Air Drop of Materiel	
ATP 6-02.53	Techniques for Tactical Radio Operations Appendix H Cosite Interference	
ATPD-2404B	Interface Standard Environmental Conditions for Ground Combat Systems	"B" Sept. 28 <sup>th</sup> , 2017
ATPD-2407	ATPD-2407, Electromagnetic Environmental Effects (E3) for US Army Tank and Automotive Vehicle Systems Tailored From MIL-STD-464C	June 25 <sup>th</sup> , 2012
MIL-STD-130N	IDENTIFICATION MARKING OF US MILITARY PROPERTY	December 17, 2007
MIL-STD-464C	ELECTROMAGNETIC ENVIRONMENTAL EFFECTSREQUIREMENTS FOR SYSTEMS	October 1 <sup>st</sup> , 2010
MIL-STD-1275E	Ground Vehicular, Electrical Power Characteristics	March 22 <sup>nd</sup> , 2013
MIL-STD-1472G	HUMAN ENGINEERING	January 11 <sup>th</sup> , 2012
CMOSS	<a href="https://spcs2.kc.army.mil/cerdec/CPI-PIT/CMOSSIPT/SitePages/Home.aspx">https://spcs2.kc.army.mil/cerdec/CPI-PIT/CMOSSIPT/SitePages/Home.aspx</a> (Formal reference documents still in work.)	evolving, target date 2023
GCIA	<a href="https://kcp.army.mil/sites/apeosei/mosa/Documents">https://kcp.army.mil/sites/apeosei/mosa/Documents</a>	evolving
SINGCARS ICD for Abrams, Bradley, Stryker	SINCGARS Interface Control Document (ICD) For Abrams Tank System, Bradley Infantry Fighting Vehicle and Stryker Brigade Combat Team	January 2004
SOSA	Technical Standard for SOSA™ (Sensor Open Systems Architecture) Reference Architecture, Edition 1.0.	July 12 <sup>th</sup> 2021
VICTORY	<a href="https://victory-standards.org/">https://victory-standards.org/</a> Please refer to this site for most current version, coordinate with PMs on component types	evolving
MIL-HDBK-419A	Grounding, Bonding, and Shielding for Electronic Equipment and Facilities Volumes 1 and 2	29 Dec 1987
MIL-STD-461G	REQUIREMENTS FOR THE CONTROL OF ELECTROMAGNETIC INTERFERENCE CHARACTERISTICS OF SUBSYSTEMS AND EQUIPMENT	11 Dec 2015
A-A-5956D	COMMERCIAL ITEM DESCRIPTION (CID): BRAID, WIRE (COPPER, TIN-COATED, SILVER-COATED, OR NICKEL COATED, TUBULAR OR FLAT)	12 Sept 2019

## 1.3. Change Log

The following changes occurred over time

Date	Change
------	--------

2020-07-20	Initial draft for review by PEOs
2020-10	<p>Added antennas &amp; amplifiers to B-Kit list, and added additional clarifying text in and around that table. Made explicit note that VICs are not covered here and are beyond the scope of SAVE –responsibility for those remains a topic of much debate. Clarified who has to provide the bolts. :-)</p> <p>Updated "RCI" to "Collins Aerospace"; updated diagrams to use generic nomenclature instead of reference to specific vendor</p> <p>Updated "TSM" to "WREN-TSM" to track anticipated future updates.</p> <p>C4ISR -&gt; C5ISR adding "Cyber" - as with CCDC C5ISR, and referencing EW capabilities that may be included. (except for VICTORY which still uses C4ISR)</p> <p>Adjusted vibration margin (aka "sway space") to 1" sides &amp; top, 2" front &amp; back, per suggestion from Abrams. to match SINCGARS Interface Control Document (ICD) For Abrams Tank System, Bradley Infantry Fighting Vehicle and Stryker Brigade Combat Team; Revision A, Jan 2004 - these values need discussion &amp; review)</p> <p>Clarified 2404A is the current standard, and added 2407 (electromagnetic requirements) there as well. Should the EM standard be MIL-STD-461A like the SINCGARS req doc?</p> <p>Added sentence to 2.5 requiring serial #s to be legible from the front without de-installing equipment.</p> <p>Added clarification of CDS requirements.</p> <p>Updated discussion of radio wiring requirements – added additional examples and text around radio wiring figures – clarified that flexibility and additional wiring is required only where practical, and that support for multiple SAVE locations is only intended for where those are adjacent. Removed some duplicate discussions on this as well.</p> <p>Added requirement to conform with standards for crypto and mission data loading. If anyone has a specific standard we can reference please let us know.</p> <p>Added reference section for technical specifications.</p> <p>Added section 4.1 about Thermal Loading - to describe additional constraints and suggestions relating to temperature.</p> <p>Added requirement to access rear cables including power &amp; headsets, with device removed, in Section 2.5 Installation &amp; Accessibility, and caveat that this document is not intended to completely cover human factors issues.</p> <p>Changed "ITN" to "CS" to keep pace with evolving N-CFT terminology.</p> <p>Updated wording for clarity and accuracy throughout - including being less specific on claims of time/cost savings, and more specific &amp; consistent in "shall" versus "should" statements.</p>
2020-10-27	Added AKit/BKit row saying that Headsets & Speakers vary by platform, per PM TR: cable loss limit is "same as LMR-400 or better"
2020-10-30	Removed thermal loading specs, too system and vehicle system of systems specific to have a general requirement here.

	Removed table of radio wiring specifications – will be added at a later time when more details are known.
2020-12-18	Removed much material with “TBD” and “TBR” statements, refining down to specific known requirements. Additional details will instead be added in the future only after they solidify. In particular the radio wiring requirements are simplified to “consult with ACMs” and “use the MBAs, wire all bands” Updated wording for clarity based on stakeholder feedback. Added legend to radio wiring figure. Removed suggestion of thumbscrews as a mounting solution that does not require tools, as it was pointed out this is not always appropriate. Replaced “Bloodhound” with “Tactical Cloud Package”. Added reference to CMFF as well as CMOSS.
2021-01-06	Final adjudication of comments from within PEO GCS prior to release to other PEOs and OCSE and Industry
2021-02-09	Added mention of AR 705-35 Criteria for Air Portability and Air Drop of Materiel, needs to survive air drop for IBCT Airborne Units as well.
2021-06	Updates to accommodate feedback from PEO C3T
2021-07	Formatting updates and wording clarification. Removed some specific information and references to specific vehicles to reduce potential sensitivity (objective is Distro A, not CUI). Added details on mounting hole pattern. Updated web link for SAVE IDD & GCIA.
2021-11	Updated connector standards to include SOSA. Added chapter 8 with suggested subdivision of the SAVE space for smaller devices, not a requirement in this version, but important to work towards efficient use of space. Final read-through and minor updates throughout for clarity based on stakeholder questions. Submitted to PEO Staffing for final review & signatures.
2022-01	Final approval received to add Distribution A markings
2022-02	Incorporated feedback from PEO C3T and PEO IEW&S. Several corrections to grammar / typos. Improved standardized usage of units throughout. Clarified that right angle mating connectors (e.g., for RF cables) must be provided and must fit within the SAVE 16.1" depth envelope. Added additional markings and replaced some drawings showing the mounting pattern to improve clarity. No change to dimensions or locations. Removed requirement for 6 pin HMI interface (was from HMS MP Gen2 PRD); this is obsolete, replaced by VICTORY standards. CMOSS changed C4ISR to C5ISR, tracking here. Note VICTORY is still C4ISR. Clarified what 2407 is relative to 461 and 464. Added clarification to environmental requirements section to address user feedback. Clarified that there is no color requirement for SAVE compliant devices, but if you want a suggestion we recommend olive drab green. :-) Finalized signature page.

