



4 Slot Conduction Cooled Chassis with Air Assist

Dual Removable Drive Bays

VITA 48.2 Advanced Thermal Solutions

AoC3U-410

Part of our line of conduction cooled enclosures with air assist, the AoC3U-410 is an ATR chassis designed to maintain safe operating temperatures for high power 3U VPX conduction cooled systems. The 410 includes dual removable drive bays for mission recording and portability. The extensible chassis design provides forced air cooling to widely available VITA 48.2 conduction cooled board sets with aggregate power demands of up to 400W. Custom and standard 4 slot backplanes (4 payload slots and 1 power supply slot) may include VPX and SOSA aligned slot profiles in combinations supporting high speed signal processing applications.

The lightweight aluminum alloy chassis is sealed to provide ingress and EMI protection. Direct connect backplane and I/O panel ensures optimal signal integrity, eliminates cabling, improves shock and vibration performance and simplifies maintenance procedures.



The AoC3U-410 is intended for use in high power, high speed C4ISR (Command, Control, Communications, Computers, Intelligence, Surveillance and Reconnaissance) systems operating in mission critical defense applications.



Removable drive bays

Up to 400W of cooling power across 4 payload slots

Features

- Cooling for up to 400W of total power
- 4 payload slots and 1 power supply slot
- Dual removable SSD bays
- Custom backplanes with VPX and SOSA aligned slot profiles
- Custom I/O panel with MIL-STD 38999 options for high speed copper, optical or RF signals
- VITA 62 pluggable power supply
- Designed to meet MIL-STD-810, MIL-STD-461, and MIL-S-901D
- Rugged bolt together construction
- Designed to meet 55C ambient temperature requirements
- Extensible design can be sized to accept a range of slot counts
- Chassis side walls contain cooling heat sink fins
- Side walls form enclosed air chambers isolated from the VPX modules
- Concentrated air flow runs co-planar to heat sink fins

Benefits

- System integration services available
- Air assist cooling stretches VITA 48.2 module usage
- Compact lightweight design for SWaP sensitive applications

SPECIFICATIONS

Physical

Dimensions: 10.00" (H), 5.9 (W) x 9.13 (D) (10.63" w/ Handle)
 Machined aluminum alloy 6061-T6, bolt together construction
 Weight: Approximately 27lbs payload dependent

Backplane options

Custom 4 +1 payload to power supply slot
 backplane VPX and SOSA aligned slot profiles
 10, 40 and 100GBase KR4 capable
 VITA 66 and 67 optical and RF apertures

Thermal

Operating: -40°C to 55°C
 4 x high cfm fans
 Max altitude 15Kft, 30Kft for sub 550W payloads
 Thermal load: Up to 400W

I/O Capabilities

Custom I/O panel supporting high speed connectivity
 High density MIL-STD 38999 circular connectors
 High speed 10GbE 38999 Hercules connectors
 Rugged SMA connectors for RF and optical I/O

Environmental

Shock: 30 Gs @ 11ms half sine
 Vibration: 20 to 2000Hz at 5Gs
 Designed to meet MIL-STD-810, MIL-STD-461, and MIL-S-901D

Payload Compatibility

3U VPX multi-core single board computers, high speed GPGPU
 and FPGA modules, video processing and Ethernet switching

Power Supply

1 VITA 62 pluggable power supply supporting 12 and 5V modules
 MIL-STD-704E, MIL-STD-1275
 Input voltage: 18 to 36 VDC
 Output: up to 700W total

Applications

Mission computing, software radio, digital recording
 systems, digital signal processing, high speed data
 acquisition, video displays in defense assets operating in
 demanding environments

Chassis Dimensions

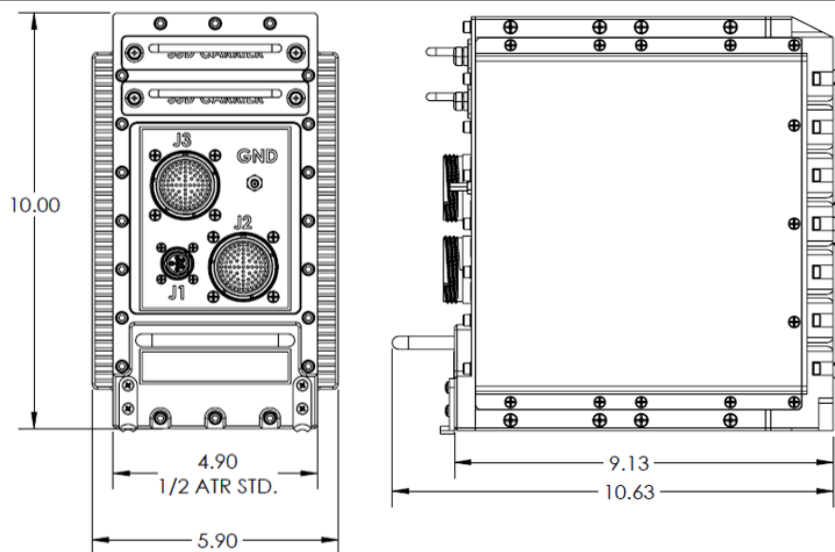

Example I/O Panel Shown

LCR provides a full line of VPX products and services - everything you need from development to deployment including; COTS rugged application ready chassis solutions as well as custom designs, custom 3U VPX backplanes supporting the latest slot profiles plus development tools including load boards and test fixtures.

ORDER NUMBER

DESCRIPTION

Consult LCR Sales

AoC3U-410 conduction cooled chassis with air assist for high power 3UVPX module payloads. Includes dual front removable drive bays. Part number and description based on final order configuration