



## The Perfect Lightweight, High-Performance UAV Solution

*The latest in processing and switching in the lightest, smallest, most rugged package*

As the role played by autonomous vehicles (airborne, ground mobile, and underwater) becomes more and more complex, the data gathering and processing demands made on their payloads and on mission and flight management has grown by leaps and bounds. Of course, this has also meant that the amount of equipment the vehicle must carry has grown as well -- and every gram of material carried by an autonomous vehicle is precious, circumscribing both its fuel and power budgets as well as its total payload.

Designed in collaboration with industry leader ADLINK, and featuring ADLINK processor boards and Graphics Processing Units (GPUs) **LCR Embedded Systems' fully integrated, conduction-cooled, featherweight 3-Slot VPX System** (shown at right) will break new ground in addressing these concerns and allow for the massive expansion of payload performance and processing power for autonomous vehicles.



The 3-Slot VPX System will feature ADLINK's VPX3010 processor based on the Intel® Xeon® D, and the second payload slot can hold either a Gigabit Ethernet switch or an ADLINK VPX3G10 Graphics Processing Unit.

- 3-Slot VITA 48.2 VPX featuring superior cooling and processing
- Super-efficient chassis design
- Available in multiple configurations for demanding sensor management applications
- Ideal for small UAVs, ground mobile

## A Gateway to the Vehicle with the Power of ADLINK's VPX3010

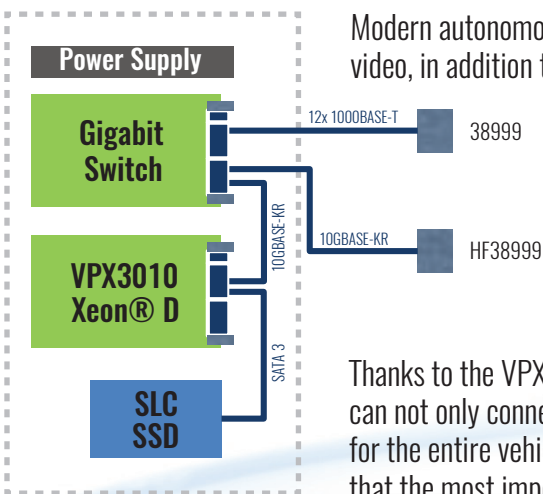

Modern autonomous vehicles can contain a multitude of sensors, including radar and multispectral video, in addition to GPS and satellite links -- all of which adds up to an enormous amount of data that cannot be feasibly communicated to the ground via a relatively low-bandwidth Tactical Radio link.

Pre-processing of this sensor and other data aboard the vehicle can often alleviate the amount of data that must be sent to the ground, with the vehicle effectively deciding which data is important enough to hand off.

Thanks to the VPX3010 Intel® Xeon® processor D card and a Gigabit Ethernet switch, this system can not only connect the various sensors to one another and function as a switched fabric backbone for the entire vehicle payload, but it can also carry out vital data processing needed to make sure that the most important data gets to where it needs to be, including offload processing for other on-board systems and encryption of the data for off-board transmission.

# The Power You Need for Multi/Hyperspectral Video/Imaging

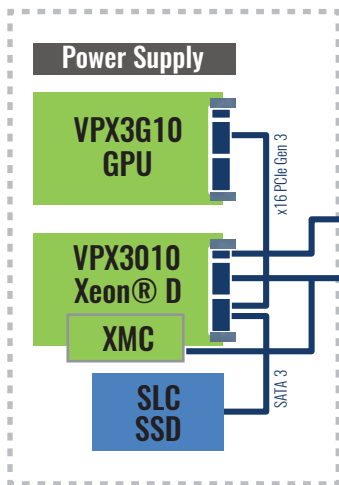

One of the biggest challenges to carrying out high-performance, processing-intensive video surveillance is the sheer amount of data involved in multi and hyperspectral video gathering used in reconnaissance, surveillance, target acquisition, and damage assessment. Data may be gathered in various spectral bands, and given the low Tactical Radio bandwidth to the ground, it can be a challenge to communicate this data to those who need it.

The ADLINK VPX3G10 Graphics Processing Unit, when used in conjunction with the VPX3010, can massively increase the data-processing capabilities of any vehicle, allowing far more sophisticated on-board algorithms, selecting only the most significant data -- speed, position, and location for example -- or communicating only the “delta” or difference between current images taken with previous satellite imagery to demonstrate how the landscape has changed.

## From Ground Control to the Vehicle, A Total Solution

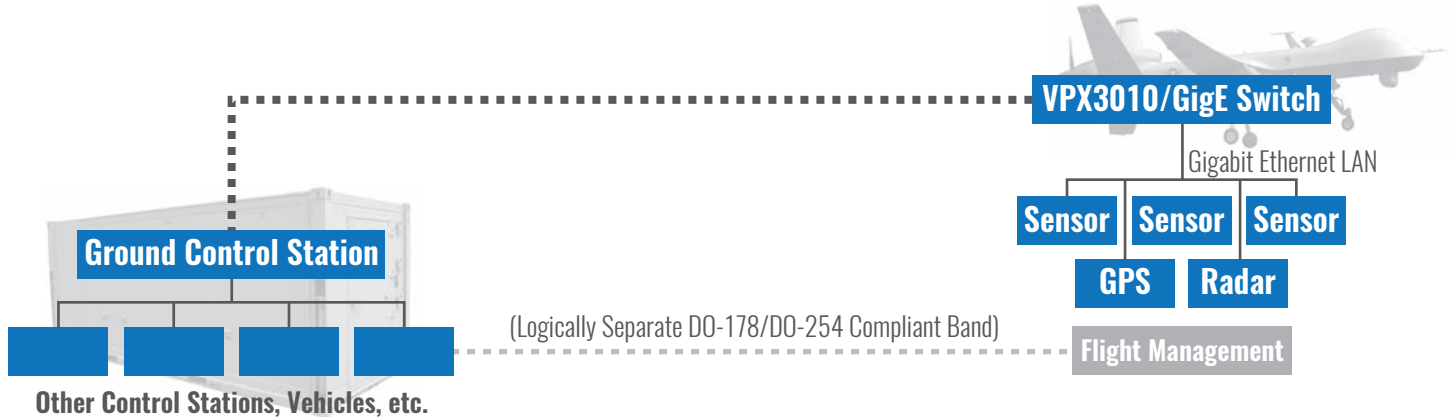

In addition to rugged, featherweight systems for UAVs of every kind, LCR Embedded Systems also designs and manufactures equipment for ground control stations, including high-performance AdvancedTCA enclosures currently in use all over the world.

Such systems function as the central brain for ground control stations and carry out image processing and data processing both to communicate to the vehicle itself as well as downstream stations and personnel. Experience like this gives LCR Embedded Systems unique expertise in designing systems for any part of a complete Unmanned Autonomous System (UAS).

While the VPX3010 processor blade carries out intensive data processing prior to downlink, the Gigabit Ethernet switch functions as a backbone for the vehicle’s entire payload. With the substitution of the VPX3G10 GPU, the vehicle can become a high-performance video platform capable of communicating the video data that matters over low-bandwidth Tactical Radio.

Sensor processing could be carried out using the Intel® CPU or by GPU-accelerated OpenCV/OpenCL and/or NVIDIA CUDA®/VisionWorks™/cuDNN.

Secure, real-time data sharing could be provided by Vortex DDS developed by PrismTech™, an ADLINK company. Vortex DDS supports the Future Airborne Capability Environment (FACE™) Consortium’s open avionics standards which are designed to make aviation computing operations more robust, interoperable, portable, and secure across military airborne platforms.